

CATALOGUE GÉNÉRAL

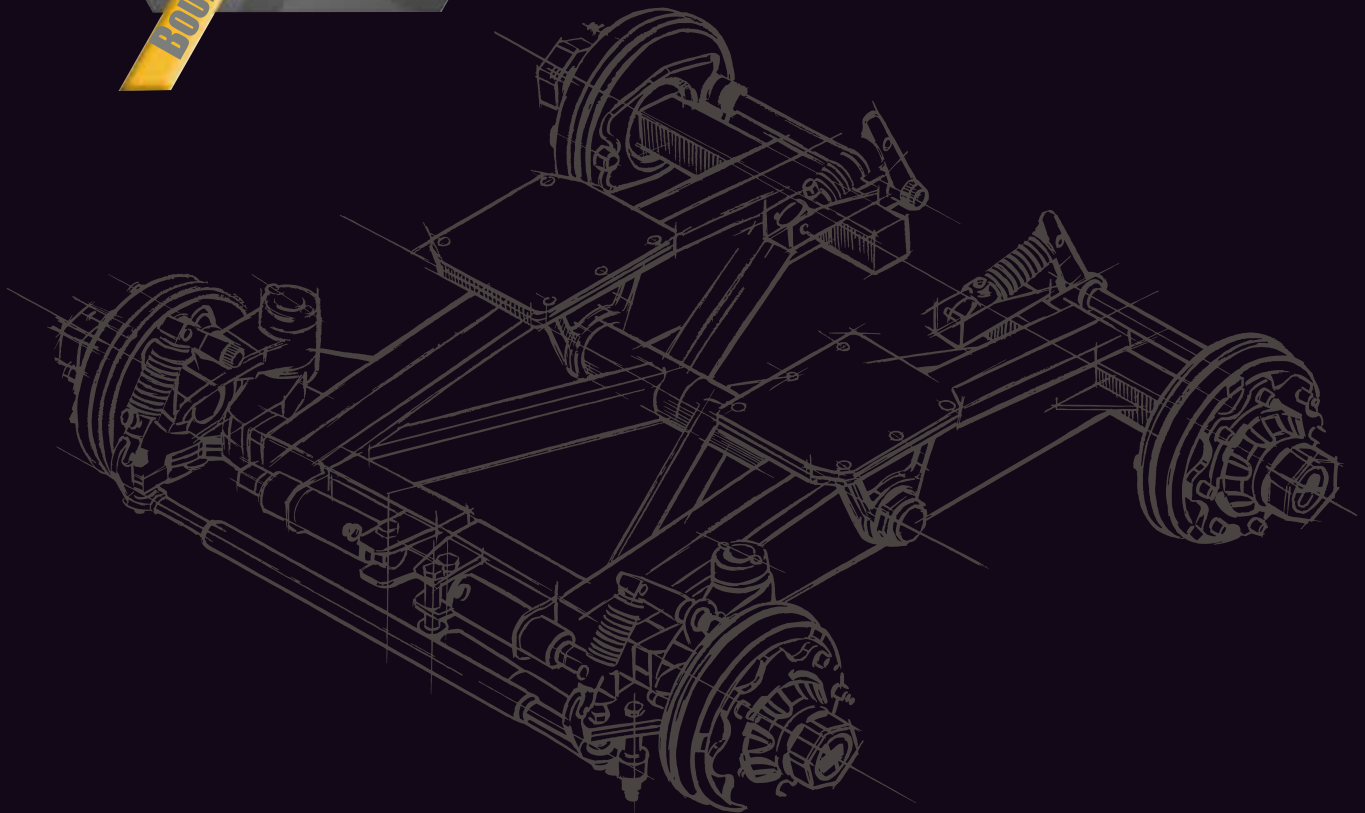

ESSIEUX BOURGOIGNE

Acteur majeur de vos performances



CATALOGUE ESSIEUX BOURGOGNE – AMB SOMMAIRE

| | |
|--|---------------|
| Présentation générale | Page 2 et 3 |
| Présentation des différents types de freins | Page 4 |
| Essieux / Demi- essieux Fixes | Page 5 à 7 |
| Essieux Suiveurs GSM1 / GSM13 / GSM2 / 2 CORPS | Page 8 à 10 |
| Boggies type Multi lames | Page 11 à 13 |
| ½ Tandems et Tandems Simplifié type Multi lames et Parabolique | Page 14 à 19 |
| ½ Tandems et Tandems à Bielles type Multi lames et Parabolique | Page 20 à 25 |
| Tridems à Bielles type Multi lames et Parabolique | Page 26 à 28 |
| Balanciers type Plié, oxycoupé et TP | Page 29 à 31 |
| Ressorts de flèche | Page 32 |
| Charges roulements coniques à rouleaux | Page 33 |
| Contres plaques Boggies | Page 34 |
| Double bridage chaise et boîtier essieux | Page 35 |
| Différents kits vérins | Page 36 |
| Dimensions des biellettes et leviers | Page 37 |
| Informations UTAC 40 KM/H | Page 38 |
| Notices de livraison et entretien | Page 39 et 40 |
| Notes | Page 41 et 44 |





PRESENTATION GENERALE

Par ce catalogue technique, nous avons le plaisir de vous présenter notre gamme d'essieux et de suspensions pour remorques et machines agricoles.

Doté de moyens d'études, de recherche et d'industrialisation, ESSIEUX BOURGOGNE développe des produits toujours plus performants, répondant ainsi aux exigences du monde agricole. Une complémentarité de compétences entre les 2 marques EB et AMB confère à notre gamme un très haut niveau de fiabilité.

Malgré toute notre vigilance dans la conception de ce catalogue, des données peuvent apparaître erronées indépendamment de notre volonté.

Les descriptions et spécifications étaient valables à la date de mise sous presse et peuvent être modifiées sans préavis et sans aucune obligation.

ESSIEUX BOURGOGNE se réserve le droit de procéder à des améliorations ou changements de conception ou d'abandonner la fabrication de pièces.



GENERAL PRESENTATION

We are proud to introduce our range of axles and suspensions for agricultural trailers and agricultural machines.

Empowered with means of research and industrialisation, ESSIEUX BOURGOGNE is continuously developing more highly capable products which comply with the requirements of the world of agriculture. A complementarity of competences between the brands EB and AMB enables our complete product range to achieve a very high standard of reliability.

We have composed this catalogue with due care. Nevertheless, some faults may occur in this catalogue independently of our will.

The descriptions and specifications were correct at the time of going to press. The information contained in this catalogue is not subject to liability and can be modified without further notice.

ESSIEUX BOURGOGNE reserves the right to make improvements or changes in the design of its products and even to abandon the production of some parts.



PRESENTACION GENERAL

Con el presente catálogo técnico, tenemos el gusto de presentarles nuestra gama de ejes y de suspensiones para remolques y maquinarias agrícolas.

Dotado con medios de estudios, de investigación e industrialización, ESSIEUX BOURGOGNE desarrolla productos cada vez más elaborados, cumpliendo así con las exigencias del mundo agrícola. La complementariedad de competencias entre las marcas EB y AMB confiere a nuestra gama un nivel de fiabilidad muy alto.

A pesar de nuestro cuidado para asegurar que todos estos datos son correctos, la introducción de errores o de inexactitudes independientemente de nuestra voluntad es posible.

Todas las descripciones y especificaciones están sujetas a cambios sin previo aviso ni obligación por parte del fabricante.

ESSIEUX BOURGOGNE se reserva el derecho de realizar mejoramientos o cambios en la concepción sus productos o de abandonar la fabricación de algunas piezas.



PRESENTATION PRODUITS
PRODUCTS PRESENTATION
PRESENTACION PRODUCTOS



ESSIEUX NON FREINES
UNBRAKED AXLES
EJES SIN FRENO



ESSIEUX FREINES
BRAKED AXLES
EJES CON FRENOS



BOGGIES FIXES ET SUIVEURS
FIXED AND STEERING BOGIES
BOGIES FIJOS Y DIRECCIONALES



TANDEMS / TRIDEMS FIXES SUIVEURS
FIXED AND STEERING TANDEMS / TRIDEMS
TANDEMS / TRIDEMS FIJOS Y DIRECCIONALES

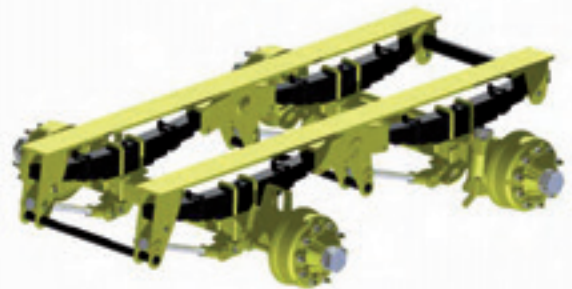

BALANCIERS PLIES ET OXYCOUPES
PENDULAR AXLES
BALANCINES

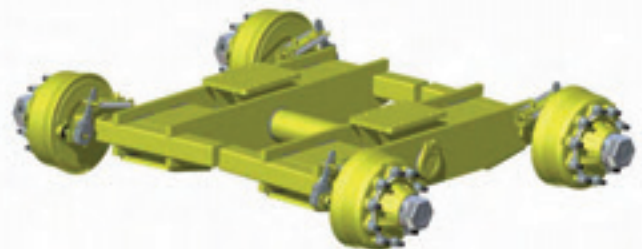



**CAPACITE FREINAGE EN HYDRAULIQUE
BRAKE CAPACITY WITH HYDRAULIC BRAKE
CAPACIDAD FRENADA CON FRENO HYDRAULICO**



DONNEES RELATIVES AU FREIN POUR UNE RECEPTION CEMAGREF 25KM/H France.

| TYPE FREIN BRAKE TYPE TIPO DE FRENO | R2 Mini Mm | R1 Maxi mm | POIDS TOTAL EN CHARGE / ESSIEU FULLY LOADED WEIGHT /AXLE PESO TOTAL BAJO VARGA / EJES | | N°CEMAGREF (25KM/H) | COUPLE CAME LEVER TORQUE PAR DE FRENADO | | | JANTE Mini WHELL Mini POUCE INCHES | ANGLE ROTATION CAME CAM ROTATION ANGLE AGULO DE ROTACION DE LALEVA DE FREINO |
|---|------------------|------------------|--|----------------------------|------------------------|---|--------------|---------------|---|---|
| | | | AVEC/WITH /CON R2 KG | AVEC/WITH /CON R1 KG | | MAXI N.m | HYDR. N.m | PNEUM. N.m | | |
| | | | 250x60 | 350 | | 450 | 7400 | 5800 | 3700 | 700 |
| 300x60 MF | 350 | 450 | 8500 | 6600 | 3701 | 700 | 470 | 567 | 15" | 20° |
| 300x60 MFG | 350 | 650 | 9100 | 4900 | 3817 | 700 | 470 | 567 | 15" | 20° |
| 350x60 | 350 | 800 | 12300 | 5900 | 15632 | 1620 | 1085 | 1312 | 18" | 20° |
| 350x90 | 350 | 800 | 13500 | 6000 | 15975 | 2200 | 1474 | 1782 | 18" | 23° |
| 400x80 | 450 | 850 | 14200 | 7500 | 13779 | 2220 | 1487 | 1798 | 19,5" | 17° |
| 406x120 | 450 | 850 | 16800 | 8900 | 12550 | 2700 | 1809 | 2187 | 20,5" | 15° |
| 406x140 | 450 | 1000 | 18800 | 8500 | 15447 | 2800 | 1876 | 2268 | 20,5" | 19,5° |
| 420x180 | 450 | 967 | 10201 | 4745 | 12/06390 | 2800 | 1867 | 2275 | 20,5" | 18° |
| 420x200 | 450 | 967 | 11213 | 5216 | 12/06391 | 2800 | 1867 | 2275 | 20,5" | 22° |

DONNEES RELATIVES AU FREIN POUR UNE RECEPTION TUV 40KM/H.

| TYPE FREIN BRAKE TYPE TIPO DE FRENO | R2 Mini mm | R1 Maxi mm | COUPLE CAME LEVER TORQUE PAR DE FRENO | GESAMTERGEBNIS PE x RE (Kgm) (VALEUR DANS LE P.V) | POIDS TOTAL EN CHARGE / ESSIEU FULLY LOADED WEIGHT / AXLE PESO TOTAL BAJO VARGA / EJES | | FACTEUR FREIN BRAKE FACTOR KENNWERT | JANTE Mini WHELL Mini POUCE INCHES | N°TUV (40KM/H) |
|---|------------------|------------------|---|---|---|----------------------------|---|---|------------------|
| | | | | | AVEC/WITH /CON R2 KG | AVEC/WITH /CON R1 KG | | | |
| | | | N.m | | K naC* | | | | |
| 250x60 | 270 | 380 | 720 | 972 | 3600 | 2558 | 0.92 | 13" | 361-0163-05 FBKV |
| 300x60 | 330 | 470 | 900 | 1600 | 4848 | 3404 | 1.16 | 15" | 361-0160-05 FBKV |
| 300x90 | 300 | 450 | 1200 | 2207 | 7357 | 4905 | 1.25 | 15" | 361-082-09 |
| 350x60 | 350 | 520 | 1500 | 2673 | 7637 | 5140 | 1.15 | 18" | 361-0043-04 FBKV |
| 350x90 | 400 | 700 | 1700 | 3815 | 9537 | 5450 | 1.1 | 18" | 361-0018-05 FBKV |
| 400x80 | 400 | 700 | 2000 | 4206 | 10515 | 6008 | 1.035 | 19,5" | 361-0067-02 FBKV |
| 406x120 | 430 | 740 | 2450 | 7206 | 16758 | 9737 | 1.45 | 20,5" | Nr AL 226.1 |
| 406x140 | 520 | 830 | 2450 | 6500 | 12500 | 7831 | 1.1 | 20,5" | 361-0030-05 FBKV |
| 420x180 | 560 | 900 | 2500 | 9234 | 14900 | 9600 | 1.25 | 20,5" | 361-055-08 |



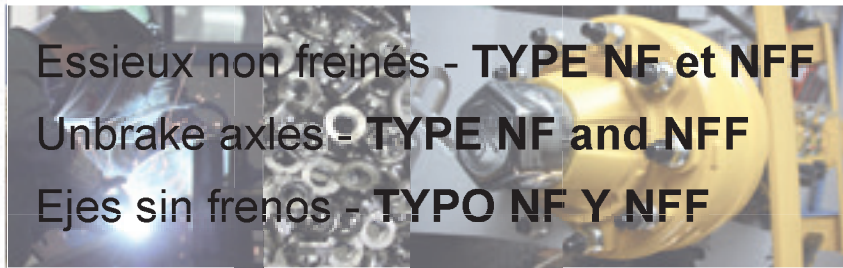

Essieux non freinés - TYPE NF et NFF
 Unbrake axles - TYPE NF and NFF
 Ejes sin frenos - TYPO NF Y NFF

ESSIEUX & 1/2 ESSIEUX
 AXLES & STUB AXLES

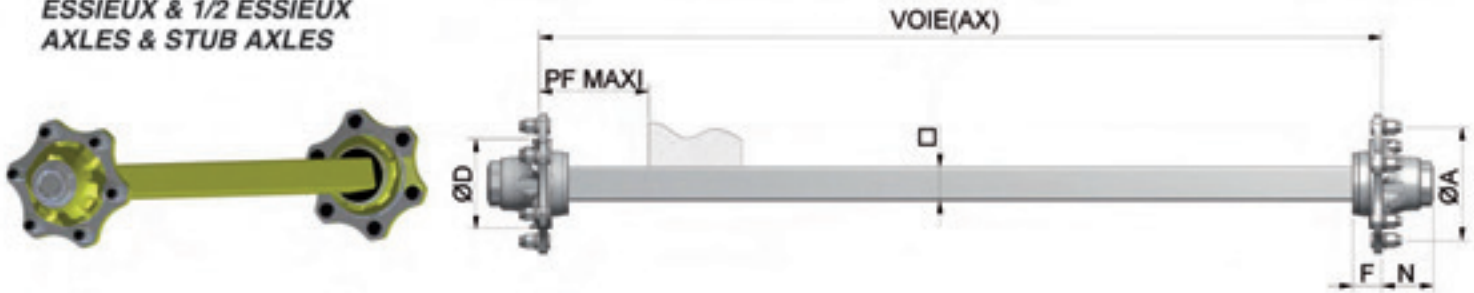

| VITESSE / SPEED / VELOCIDAD | | | 25 km/h | | | 40 km/h | | | ROUEMENTS BEARINGS RODAMIENTOS | AXES DE ROUE WHEEL STUDS ATAQUE | | | | | |
|---|---------------------------|--------------------------------------|--|-------|-------|---------|-------|-------|--------------------------------------|---------------------------------------|----|-----|-----|----|-----|
| DESIGNATION TRADE NAME NOMBRAMIENTO | CARRE SQUARE CUADRO | PORTE A FAUX OVERHANG VOLADIZO | CHARGE SUR ESSIEU / LOAD ON AXLE / CARGA | | | | | | | NB | Ø | A | D | F | N |
| | | | | | | | | | | | | | | | |
| □ mm | PF mm | kg | kg | kg | kg | kg | kg | | | | | | | | |
| 3504 NF | □35 | 170 | 650 | 1000 | 450 | 450 | 750 | 350 | 30205/30205 | | | | | | |
| 4004 NF | □40 | 180 | 1450 | 1800 | 1250 | 1250 | 1550 | 1150 | 30205/30207 | 4 | 16 | 130 | 84 | 42 | 71 |
| 4005 NF | □40 | 170 | 1450 | 1800 | 1250 | 1250 | 1550 | 1150 | 30205/30207 | 5 | 16 | 140 | 94 | 42 | 71 |
| 5005 NF | □50 | 170 | 2500 | 3100 | 1900 | 1900 | 2400 | 1600 | 30206/30209 | 5 | 16 | 140 | 94 | 46 | 74 |
| 5006 NFF | □50 | 170 | 2900 | 3500 | 2300 | 2300 | 2800 | 2000 | 30206/30209 | 6 | 18 | 205 | 160 | 46 | 74 |
| 6006 NFF | □60 | 200 | 4100 | 5000 | 3300 | 3300 | 4300 | 2800 | 30208/30211 | 6 | 18 | 205 | 160 | 52 | 92 |
| 7006 NFF | □70 | 230 | 5500 | 6500 | 4500 | 4500 | 5500 | 4000 | 30208/32013 | 6 | 18 | 205 | 160 | 52 | 92 |
| 7008 NFF | □70 | 230 | 6500 | 7500 | 5500 | 5500 | 6500 | 4500 | 32210/30213 | 8 | 18 | 275 | 220 | 62 | 119 |
| 8006 NFF | □80 | 270 | 7000 | 8000 | 6000 | 6000 | 7000 | 5500 | 32211/32214 | 6 | 18 | 205 | 160 | 68 | 116 |
| 8008 NFF | □80 | 270 | 7200 | 8200 | 6200 | 6200 | 7200 | 5700 | 32212/32215 | 8 | 18 | 275 | 220 | 88 | 133 |
| 9008 NFF | □90 | 310 | 8400 | 10200 | 7400 | 7400 | 8400 | 6900 | 32212/32216 | 8 | 18 | 275 | 220 | 94 | 135 |
| 9010 NFF | □90 | 310 | 8400 | 10200 | 7400 | 7400 | 8400 | 6900 | 32212/32216 | 10 | 22 | 335 | 280 | 78 | 132 |
| 1008 NFF | □100 | 330 | 12000 | 13000 | 10500 | 12000 | 13000 | 10500 | 32215/32218 | 8 | 18 | 275 | 220 | 93 | 161 |
| 1010 NFF | □100 | 330 | 12000 | 13000 | 10500 | 12000 | 13000 | 10500 | 32215/32218 | 10 | 22 | 335 | 280 | 93 | 173 |
| 1110 NFF | □110 | 360 | 15000 | 16000 | 14000 | 15000 | 16000 | 14000 | 32215/33021 | 10 | 22 | 335 | 280 | 93 | 173 |
| 1310 NFF | □130 | 360 | 15000 | 16000 | 14000 | 15000 | 16000 | 14000 | 32215/33021 | 10 | 22 | 335 | 280 | 93 | 173 |
| 1510 NFF | □150 | 390 | 18000 | 19000 | 17000 | 18000 | 19000 | 17000 | 33017/33021 | 10 | 22 | 335 | 280 | 93 | 173 |

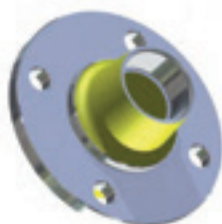

MOYEU
TYPE NF

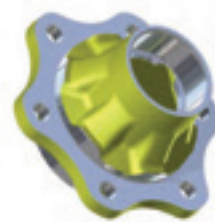

MOYEU
TYPE NFF



ESSIEUX BOURGOGNE





Essieux freinés – TYPE MF et MFG
Brake axles – TYPE MF and MFG
Ejes con frenos – TIPO MF y MFG



ESSIEUX & 1/2 ESSIEUX
AXLES & STUB AXLES

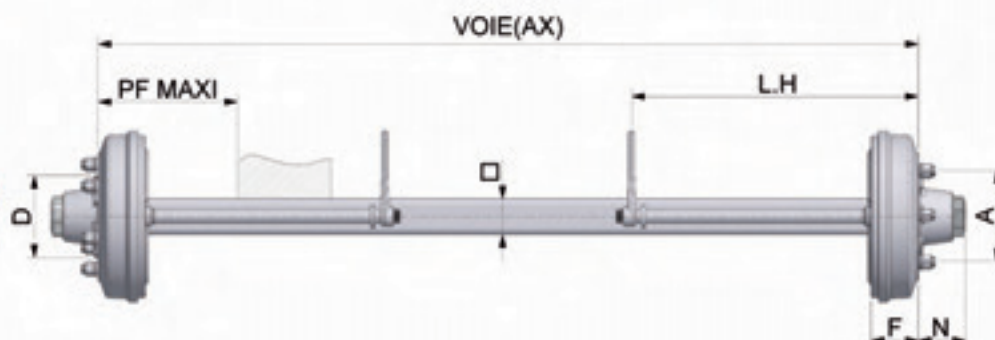

| VITESSE / SPEED / VELOCIDAD | | | 25 km/h | | | 40 km/h | | | ROULEMENTS BEARINGS RODAMIENTOS | AXES DE ROUE WHEEL STUDS ATAQUE | | | | | |
|---|---------------------------|--------------------------------------|--|------|------|---------|------|------|---------------------------------------|---------------------------------------|----|-----|-----|-----|-----|
| DESIGNATION TRADE NAME NOMBRAMIENTO | CARRE SQUARE CUADRO | PORTE A FAUX OVERHANG VOLADIZO | CHARGE SUR ESSIEU / LOAD ON AXLE / CARGA | | | | | | | NB | Ø | A | D | F | N |
| | □ mm | PF mm | | | | | | | | | | | | | |
| 5005 MF 250 | □50 | 170 | 2900 | 3500 | 2300 | 2300 | 2800 | 2000 | 30206/30209 | 5 | 16 | 140 | 94 | 86 | 74 |
| 5006 MF 250 | □50 | 170 | 2900 | 3500 | 2300 | 2300 | 2800 | 2000 | 30206/30209 | 6 | 18 | 205 | 160 | 86 | 74 |
| 6006 MF 250 | □60 | 200 | 4100 | 5000 | 3300 | 3300 | 4300 | 2800 | 30208/30211 | 6 | 18 | 205 | 160 | 86 | 92 |
| 6006 MF 300 | □60 | 200 | 4100 | 5000 | 3300 | 3300 | 4300 | 2800 | 30208/30211 | 6 | 18 | 205 | 160 | 92 | 92 |
| 7006 MF 250 | □70 | 230 | 5500 | 6500 | 4500 | 4500 | 5500 | 4000 | 30208/32013 | 6 | 18 | 205 | 160 | 86 | 92 |
| 7006 MF 300 | □70 | 230 | 5500 | 6500 | 4500 | 4500 | 5500 | 4000 | 30208/32013 | 6 | 18 | 205 | 160 | 92 | 92 |
| 8006 MF250 | □80 | 270 | 5500 | 6500 | 4500 | 4500 | 5500 | 4000 | 30208/32013 | 6 | 18 | 205 | 160 | 86 | 92 |
| 8006 MF 300 | □80 | 270 | 5500 | 6500 | 4500 | 4500 | 5500 | 4000 | 30208/32013 | 6 | 18 | 205 | 160 | 92 | 92 |
| 8008 MF 350 * | □80 | 270 | 7200 | 8200 | 6200 | 6200 | 7200 | 5700 | 32211/32214 | 8 | 18 | 275 | 220 | 109 | 128 |
| 7006 MFG 250 | □70 | 230 | 5000 | 6000 | 4000 | 4000 | 5000 | 3000 | 30208/32013 | 6 | 18 | 205 | 160 | 86 | 92 |
| 7006 MFG 300 | □70 | 230 | 5500 | 6500 | 4500 | 4500 | 5500 | 4000 | 32210/30213 | 6 | 18 | 205 | 160 | 90 | 121 |
| 8006 MFG 300 | □80 | 270 | 7000 | 8000 | 6000 | 6000 | 7000 | 5500 | 32211/32214 | 6 | 18 | 205 | 160 | 90 | 121 |

- * Avec roue de 18" maximum
- * With 18 inches Wheel maximum
- * Con ruedas de 18" máximo





Essieux freinés — TYPE FF
 Brake axles — TYPE FF
 Ejes con frenos — TIPO FF



**ESSIEUX & 1/2 ESSIEUX
 AXLES & STUB AXLES**

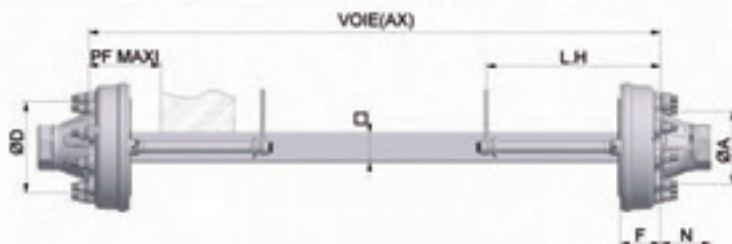
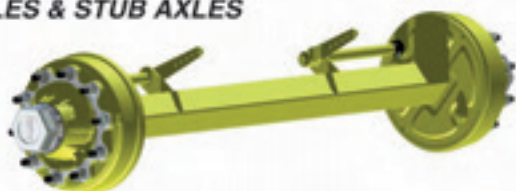

| VITESSE / SPEED / VELOCIDAD | | | 25 km/h | | | 40 km/h | | | ROUEMENTS BEARINGS RODAMIENTOS | AXES DE ROUE WHEEL STUDS ATAQUE | | | | | |
|-----------------------------|------------------------------|--------------------------------------|--|-------|-------|---------|-------|-------|--------------------------------------|---------------------------------------|----|-----|-----|-----|-----|
| DESIGNATION | CARRE SQUARE CUADRADRO | PORTE A FAUX OVERHANG VOLADIZO | CHARGE SUR ESSIEU / LOAD ON AXLE / CARGA | | | | | | | NB | Ø | A | D | F | N |
| TRADE NAME | | | | | | | | | | | | | | | |
| NOMBRAMIENTO | □ mm | PF mm | kg | kg | kg | kg | kg | kg | | | | | | | |
| 7008 FF 350x60 | □70 | 230 | 5500 | 6500 | 4500 | 4500 | 5500 | 4000 | 32210/30213 | 8 | 18 | 275 | 220 | 111 | 119 |
| 8008 FF 350x60 | □80 | 270 | 7200 | 8200 | 6200 | 6200 | 7200 | 5700 | 32212/32215 | 8 | 18 | 275 | 220 | 112 | 133 |
| 8008 FF 350x90 | □80 | 270 | 7200 | 8200 | 6200 | 6200 | 7200 | 5700 | 32212/32215 | 8 | 18 | 275 | 220 | 166 | 133 |
| 8008 FF 400x80 | □80 | 270 | 7200 | 8200 | 6200 | 6200 | 7200 | 5700 | 32212/32215 | 8 | 18 | 275 | 220 | 134 | 133 |
| 9008 FF 350x60 | □90 | 310 | 8400 | 10200 | 7400 | 7400 | 8400 | 6900 | 32212/32216 | 8 | 18 | 275 | 220 | 112 | 134 |
| 9008 FF 350x90 | □90 | 310 | 8400 | 10200 | 7400 | 7400 | 8400 | 6900 | 32212/32216 | 8 | 18 | 275 | 220 | 166 | 134 |
| 9008 FF 400x80 | □90 | 310 | 8400 | 10200 | 7400 | 7400 | 8400 | 6900 | 32212/32216 | 8 | 18 | 275 | 220 | 134 | 134 |
| 9008 FF 406x120 | □90 | 310 | 8400 | 10200 | 7400 | 7400 | 8400 | 6900 | 32212/32216 | 8 | 18 | 275 | 220 | 178 | 134 |
| 9010 FF 400x80 | □90 | 310 | 8400 | 10200 | 7400 | 7400 | 8400 | 6900 | 32212/32216 | 10 | 22 | 335 | 280 | 135 | 132 |
| 9010 FF 406x120 | □90 | 310 | 8400 | 10200 | 7400 | 7400 | 8400 | 6900 | 32212/32216 | 10 | 22 | 335 | 280 | 179 | 132 |
| 9010 FF 406x140 | □90 | 310 | 8400 | 10200 | 7400 | 7400 | 8400 | 6900 | 32212/32216 | 10 | 22 | 335 | 280 | 194 | 132 |
| 1008 FF 350x60 | □100 | 330 | 12000 | 13000 | 10500 | 12000 | 13000 | 10500 | 32215/32218 | 8 | 18 | 275 | 220 | 112 | 134 |
| 1008 FF 350x90 | □100 | 330 | 12000 | 13000 | 10500 | 12000 | 13000 | 10500 | 32215/32218 | 8 | 18 | 275 | 220 | 170 | 161 |
| 1008 FF 400x80 | □100 | 330 | 12000 | 13000 | 10500 | 12000 | 13000 | 10500 | 32215/32218 | 8 | 18 | 275 | 220 | 138 | 161 |
| 1008 FF 406x120 | □100 | 330 | 12000 | 13000 | 10500 | 12000 | 13000 | 10500 | 32215/32218 | 8 | 18 | 275 | 220 | 182 | 161 |
| 1010 FF 400x80 | □100 | 330 | 12000 | 13000 | 10500 | 12000 | 13000 | 10500 | 32215/32218 | 10 | 22 | 335 | 280 | 138 | 173 |
| 1010 FF 406x120 | □100 | 330 | 12000 | 13000 | 10500 | 12000 | 13000 | 10500 | 32215/32218 | 10 | 22 | 335 | 280 | 182 | 173 |
| 1010 FF 406x140 | □100 | 330 | 12000 | 13000 | 10500 | 12000 | 13000 | 10500 | 32215/32218 | 10 | 22 | 335 | 280 | 197 | 173 |
| 1110 FF 400x80 | □110 | 360 | 15000 | 16000 | 14000 | 15000 | 16000 | 14000 | 32215/33021 | 10 | 22 | 335 | 280 | 138 | 173 |
| 1110 FF 406x120 | □110 | 360 | 15000 | 16000 | 14000 | 15000 | 16000 | 14000 | 32215/33021 | 10 | 22 | 335 | 280 | 182 | 173 |
| 1110 FF 406x140 | □110 | 360 | 15000 | 16000 | 14000 | 15000 | 16000 | 14000 | 32215/33021 | 10 | 22 | 335 | 280 | 197 | 173 |
| 1310 FF 400x80 | □130 | 360 | 15000 | 16000 | 14000 | 15000 | 16000 | 14000 | 32215/33021 | 10 | 22 | 335 | 280 | 182 | 173 |
| 1310 FF 406x120 | □130 | 360 | 15000 | 16000 | 14000 | 15000 | 16000 | 14000 | 32215/33021 | 10 | 22 | 335 | 280 | 197 | 173 |
| 1310 FF 406x140 | □130 | 360 | 15000 | 16000 | 14000 | 15000 | 16000 | 14000 | 32215/33021 | 10 | 22 | 335 | 280 | 182 | 173 |
| 1510 FF 406x120 | □150 | 390 | 18000 | 19000 | 17000 | 18000 | 19000 | 17000 | 33017/33021 | 10 | 22 | 335 | 280 | 182 | 173 |
| 1510 FF 406x140 | □150 | 390 | 18000 | 19000 | 17000 | 18000 | 19000 | 17000 | 33017/33021 | 10 | 22 | 335 | 280 | 197 | 173 |
| 1510 FF 420x180 | □150 | 390 | 18000 | 19000 | 17000 | 18000 | 19000 | 17000 | 33017/33021 | 10 | 22 | 335 | 280 | 247 | 173 |
| 1510 FF 420x200 | □150 | 390 | 18000 | 19000 | 17000 | 18000 | 19000 | 17000 | 33017/33021 | 10 | 22 | 335 | 280 | 279 | 173 |





Essieux Suiveurs – TYPE GSM1/GSM13
 Steering axles – TYPE GSM1/GSM13
 Ejes Direccional – TIPO GSM1/GSM13



ESSIEUX & 1/2 ESSIEUX
 AXLES & STUB AXLES

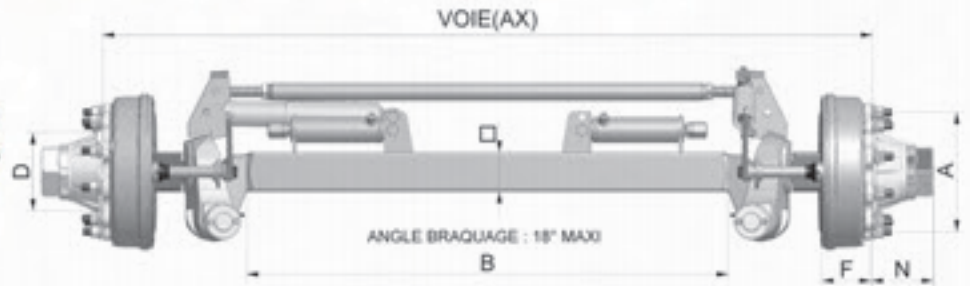

| VITESSE / SPEED / VELOCIDAD | | | 25 km/h | 40 km/h | ROULEMENTS BEARINGS RODAMIENTOS | AXES DE ROUE WHEEL STUDS ATAQUE | | | | | |
|---|---------------------------|--------|--|---------|---------------------------------------|---------------------------------------|----|-----|-----|-----|-----|
| DESIGNATION TRADE NAME NOMBRAMIENTO | CARRE SQUARE CUADRO | B | CHARGE SUR ESSIEU / LOAD ON AXLE / CARGA | | | NB | Ø | A | D | F | N |
| | | | | | | | | | | | |
| | | kg | kg | | | | | | | | |
| GSM1 | mm | mm | kg | kg | | | | | | | |
| 8008 FF 350x60 | □80 | AX-700 | 7500 | 7000 | 32212/32215 | 8 | 18 | 275 | 220 | 112 | 133 |
| 9008 FF 350x60 | □90 | AX-700 | 8000 | 7500 | 32212/32216 | 6 | 18 | 275 | 220 | 112 | 134 |
| 9008 FF 350x90 | □90 | AX-700 | 8000 | 7500 | 32212/32216 | 8 | 18 | 275 | 220 | 166 | 134 |
| 9008 FF 400x80 | □90 | AX-700 | 8000 | 7500 | 32212/32216 | 8 | 18 | 275 | 220 | 134 | 134 |
| 1008 FF 350x60 | □100 | AX-700 | 9000 | 8500 | 32215/32218 | 8 | 18 | 275 | 220 | 112 | 134 |
| 1008 FF 350x90 | □100 | AX-700 | 9000 | 8500 | 32215/32218 | 8 | 18 | 275 | 220 | 170 | 161 |
| 1008 FF 400x80 | □100 | AX-700 | 9000 | 8500 | 32215/32218 | 8 | 18 | 275 | 220 | 138 | 161 |
| 1010 FF 400x80 | □100 | AX-700 | 11000 | 9500 | 32215/32218 | 10 | 22 | 335 | 280 | 138 | 173 |
| 1010 FF 406x120 | □100 | AX-800 | 11000 | 9500 | 32215/32218 | 10 | 22 | 335 | 280 | 182 | 173 |
| 1010 FF 406x140 | □100 | AX-800 | 11000 | 9500 | 32215/32218 | 10 | 22 | 335 | 280 | 197 | 173 |
| 1110 FF 400x80 | □110 | AX-700 | 12500 | 11000 | 32215/33021 | 10 | 22 | 335 | 280 | 138 | 173 |
| 1110 FF 406x120 | □110 | AX-800 | 12500 | 11000 | 32215/33021 | 10 | 22 | 335 | 280 | 182 | 173 |
| 1110 FF 406x140 | □110 | AX-800 | 12500 | 11000 | 32215/33021 | 10 | 22 | 335 | 280 | 197 | 173 |
| GSM13 | | | | | | | | | | | |
| 1310 FF 400x80 | □130 | AX-750 | 12500 | 11000 | 32215/33021 | 10 | 22 | 335 | 280 | 197 | 173 |
| 1310 FF 406x120 | □130 | AX-900 | 12500 | 11000 | 32215/33021 | 10 | 22 | 335 | 280 | 197 | 173 |
| 1310 FF 406x140 | □130 | AX-900 | 12500 | 11000 | 32215/33021 | 10 | 22 | 335 | 280 | 197 | 173 |

ARTICULATION GSM1 / GSM13

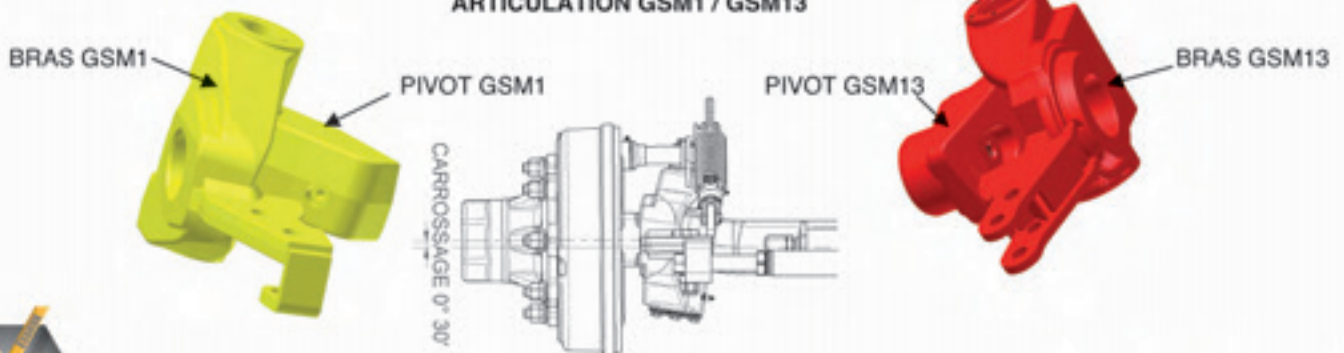



Essieux Suiveurs – TYPE GSM2
 Steering axles – TYPE GSM2
 Ejes Direccional – TIPO GSM2



**ESSIEUX & 1/2 ESSIEUX
 AXLES & STUB AXLES**

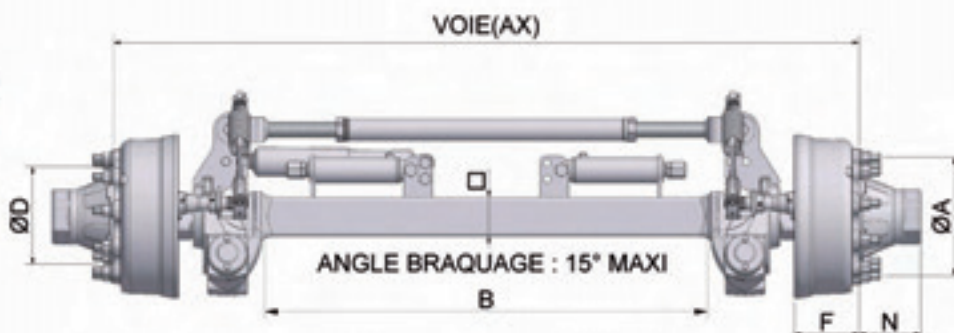
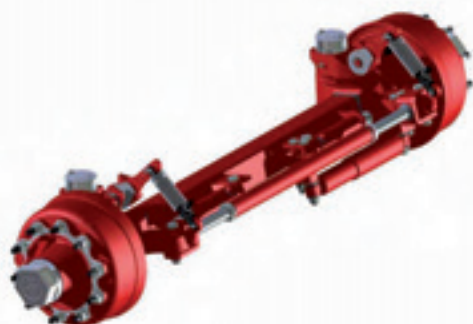

| VITESSE / SPEED / VELOCIDAD | | | 25 km/h | 40 km/h | ROULEMENTS BEARINGS RODAMIENTOS | AXES DE ROUE WHEEL STUDS ATAQUE | | | | | |
|---|---------------------------|--------|--|---------|---------------------------------------|---------------------------------------|----|-----|-----|-----|-----|
| DESIGNATION TRADE NAME NOMBRAMIENTO | CARRE SQUARE CUADRO | B | CHARGE SUR ESSIEU / LOAD ON AXLE / CARGA | | | NB | Ø | A | D | F | N |
| | | | | | | | | | | | |
| GSM2 | mm | mm | kg | kg | | | | | | | |
| 1510 FF 406x120 | □150 | AX-830 | 16000 | 14500 | 33017/33021 | 10 | 22 | 335 | 280 | 182 | 173 |
| 1510 FF 406x140 | □150 | AX-830 | 16000 | 14500 | 33017/33021 | 10 | 22 | 335 | 280 | 197 | 173 |
| 1510 FF 420x180 | □150 | AX-880 | 16000 | 14500 | 33017/33021 | 10 | 22 | 335 | 280 | 247 | 173 |
| 1510 FF 420x200 | □150 | AX-980 | 16000 | 14500 | 33017/33021 | 10 | 22 | 335 | 280 | 279 | 173 |

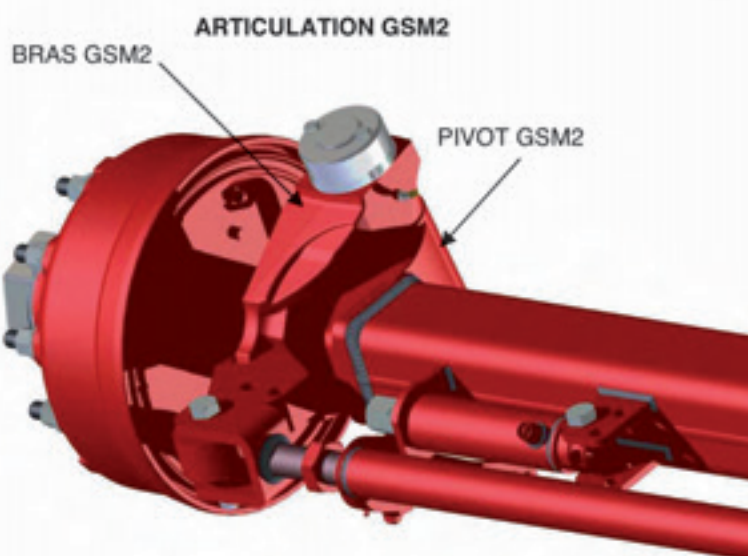



Essieux Suiveurs – TYPE 2 CORPS
 Steering axles – TYPE 2 BODIES
 Ejes Direccional – TIPO 2 CUERPOS

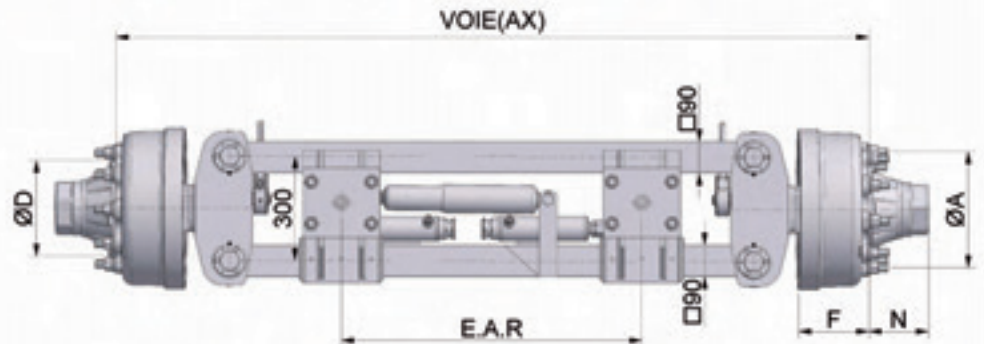
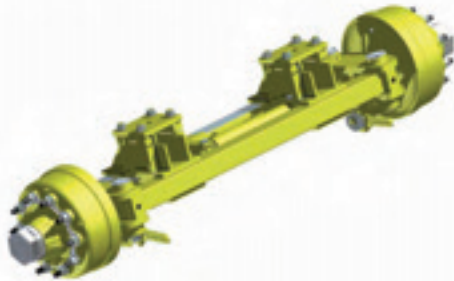

| VITESSE / SPEED / VELOCIDAD | | | 25 km/h | 40 km/h | ROULEMENTS BEARINGS RODAMIENTOS | AXES DE ROUE WHEEL STUDS ATAQUE | | | | | |
|-----------------------------|-----------------|--------|--|---------|---------------------------------------|---------------------------------------|----|-----|-----|-----|-----|
| DESIGNATION | CARRE SQUARE | B | CHARGE SUR ESSIEU / LOAD ON AXLE / CARGA | | | NB | Ø | A | D | F | N |
| TRADE NAME | CUADRADRO | | | | | | | | | | |
| NOMBRAMIENTO | | kg | kg | | | | | | | | |
| 2 CORPS | mm | mm | | | | | | | | | |
| 1010 FF 400x80 | □100 | AX-500 | 11000 | 9500 | 32215/32218 | 10 | 22 | 335 | 280 | 138 | 173 |
| 1010 FF 406x120 | □100 | AX-600 | 11000 | 9500 | 32215/32218 | 10 | 22 | 335 | 280 | 182 | 173 |
| 1010 FF 406x140 | □100 | AX-600 | 11000 | 9500 | 32215/32218 | 10 | 22 | 335 | 280 | 197 | 173 |
| 1110 FF 400x80 | □110 | AX-500 | 12500 | 11000 | 32215/33021 | 10 | 22 | 335 | 280 | 138 | 173 |
| 1110 FF 406x120 | □110 | AX-600 | 14000 | 13000 | 32215/33021 | 10 | 22 | 335 | 280 | 182 | 173 |
| 1110 FF 406x140 | □110 | AX-600 | 14000 | 13000 | 32215/33021 | 10 | 22 | 335 | 280 | 197 | 173 |
| 1210 FF 406x120 | □120 | AX-600 | 16000 | 14500 | 33017/33021 | 10 | 22 | 335 | 280 | 182 | 173 |
| 1210 FF 406x140 | □120 | AX-600 | 16000 | 14500 | 33017/33021 | 10 | 22 | 335 | 280 | 197 | 173 |

FR **SIMPLE et ROBUSTE** pour les gros tonnages (9 à 16T), il assure une meilleure répartition de la charge sur deux corps d'essieux au lieu d'un. Les articulations **DOUBLEES** diminuent les charges de moitié au niveau des bagues et des axes de pivotements. La géométrie des articulations supprime l'effet de ripage des roues sur le sol, augmentant ainsi la durée de vie des pneumatiques.

UK **SIMPLE and STURDY** for large tonnages (9 to 16 tons) it allows a better distribution of the load on 2 axles bodies instead of one. The double articulation cuts the load on the bushings and pivot shafts in two. The geometry of the articulations eliminates the effect of the tyre scrubbing, thus increasing the life span of the tyres.

ES **SENCILLO y ROBUSTO** para grandes tonelajes (de 9T a 16T), asegura una mejor repartición de la carga sobre dos cuerpos de ejes en vez de uno. Sus dobles articulaciones disminuyen a la mitad las cargas tanto al nivel de los anillos como de los ejes de pivote. La geometría de las articulaciones elimina el efecto de deslizamiento de las ruedas sobre el suelo, aumentando así la duración de vida de los neumáticos.





BOGGIES FIXES
FIXED BOGIES
BOGIES FIJOS

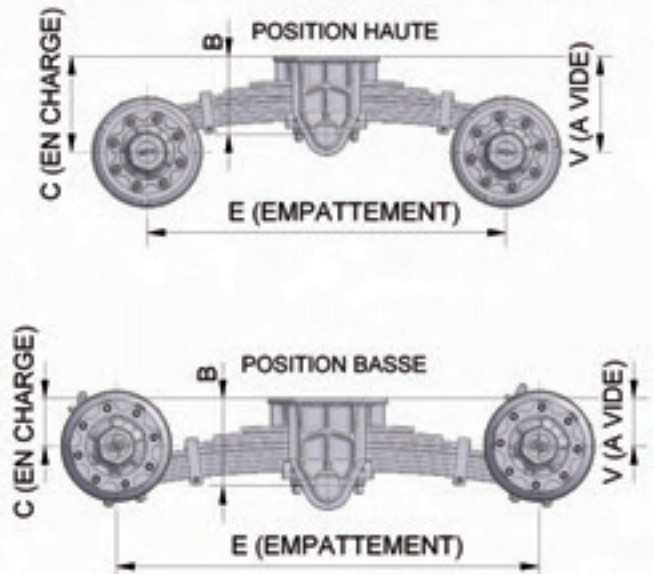
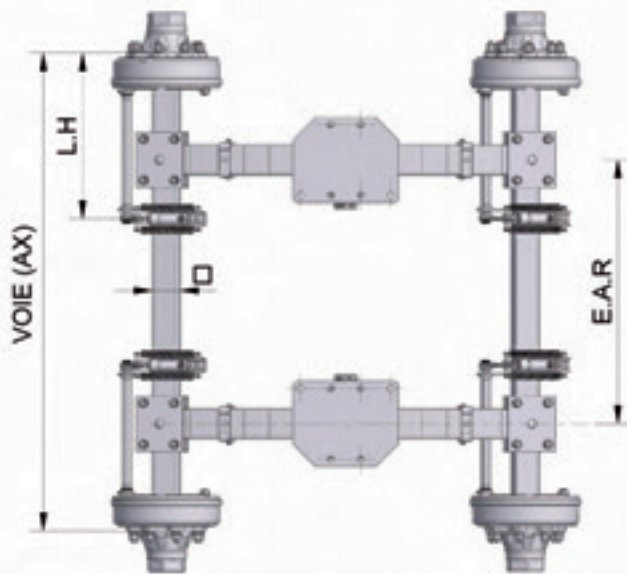

| CHARGE/LOAD /CARGA | CARRE SQUARE CUADADRO | TYPE RESSORT TYPE SPRING BALLESTA | EMPATTEMENT E (mm) | B | E.A.R MAX | POSITION HAUTE | | POSITION BASSE | |
|-----------------------|-----------------------------|---|---------------------------|-----|-----------|----------------|---------|----------------|---------|
| | | | | | | V | C | V | C |
| KGS | □ | NB - L x EP. (mm) | | mm | mm | mm | | | |
| 9 000 | □70 | 6/3 - 100 x 14 | 1050 / 1200 | 130 | AX-500 | 245/265 | 185/205 | 100/120 | 40/60 |
| 10 000 | □80 | 7/3 - 100 x 14 | 1050 / 1200 | 200 | AX-500 | 260/270 | 200/210 | 110/130 | 50/70 |
| 12 000 | □80 | 5/3 - 120 x 20 | 1200 / 1370 | 250 | AX-500 | 295/315 | 235/255 | 115/135 | 55/75 |
| 14 000 | □90 | 6/3 - 120 x 20 | 1200 / 1370 | 250 | AX-500 | 300/330 | 240/270 | 110/130 | 50/70 |
| 16 000 | □90 | 7/3 - 120 x 20 | 1200 / 1370 | 280 | AX-500 | 330/350 | 270/290 | 140/160 | 80/100 |
| 16 000 | □90 | 8/4 - 120 x 20 | 1450 | 310 | AX-500 | 375 | 315 | 160 | 100 |
| 18 000 | □100 | 8/4 - 120 x 20 | 1450 | 310 | AX-500 | 380 | 320 | 165 | 105 |
| 21 000 | □110 | 9/4 - 120 x 20 | 1450 / 1550 | 350 | AX-500 | 410/430 | 350/370 | 180/200 | 120/140 |
| 21 000 | □110 | 10/4 - 120 x 20 | 1450 / 1550 | 350 | AX-500 | 430/440 | 370/380 | 190/210 | 130/150 |
| 21 000 | □110 | 10/5 - 120 x 20 | 1450 / 1550 | 350 | AX-600 | 420/440 | 360/380 | 190/210 | 130/150 |
| 23 000 | □110 | 11/4 - 120 x 20 | 1550 / 1650 | 370 | AX-600 | 440/450 | 380/390 | 220/230 | 160/170 |
| 21 000 | □130 | 9/4 - 120 x 20 | 1450 / 1550 | 350 | AX-500 | 420/440 | 360/380 | 190/210 | 130/150 |
| 21 000 | □130 | 10/4 - 120 x 20 | 1450 / 1550 | 350 | AX-500 | 440/450 | 380/390 | 200/220 | 140/160 |
| 21 000 | □130 | 10/5 - 120 x 20 | 1450 / 1550 | 350 | AX-600 | 430/450 | 370/390 | 200/220 | 140/160 |
| 23 000 | □130 | 11/4 - 120 x 20 | 1550 / 1650 | 370 | AX-600 | 450/460 | 390/400 | 230/240 | 170/180 |
| 23 000 | □150 | 11/4 - 120 x 20 | 1650 / 1750 | 370 | AX-600 | 460/470 | 400/410 | 210/220 | 150/160 |

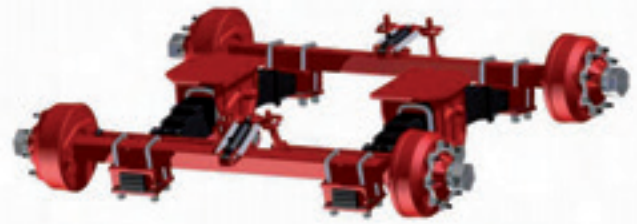



BOGGIES AVEC ESSIEU SUIVEUR
BOGIES WITH STEERING AXLE
BOGIES CON EJE DIRECCIONAL

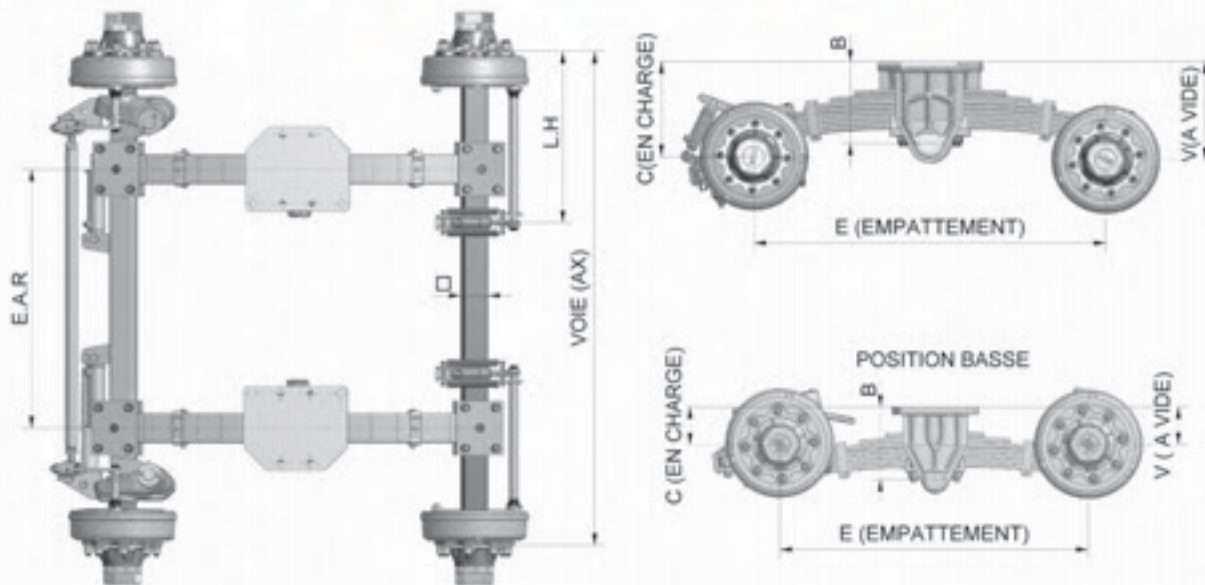

| CHARGE/LOAD /CARGA | CARRE SQUARE CUADRO | TYPE RESSORT TYPE SPRING BALLESTA | EMPATTEMENT E (mm) | B | E.A.R MAX | POSITION HAUTE | | POSITION BASSE | |
|-----------------------|---------------------------|---|-----------------------|-----|-----------|----------------|---------|----------------|---------|
| | | | | | | V | C | V | C |
| KGS | □ | NB - L x EP. (mm) | | mm | mm | mm | | | |
| 12 000 | □90 | 5/3 - 120 x 20 | 1200 / 1370 | 250 | AX-950 | 295/315 | 235/255 | 115/135 | 55/75 |
| 14 000 | □90 | 6/3 - 120 x 20 | 1200 / 1370 | 250 | AX-950 | 300/330 | 240/270 | 110/130 | 50/70 |
| 16 000 | □90 | 7/3 - 120 x 20 | 1200 / 1370 | 280 | AX-950 | 330/350 | 270/290 | 140/160 | 80/100 |
| 16 000 | □90 | 8/4 - 120 x 20 | 1450 | 310 | AX-950 | 375 | 315 | 160 | 100 |
| 18 000 | □100 | 8/4 - 120 x 20 | 1450 | 310 | AX-1050 | 380 | 320 | 165 | 105 |
| 21 000 | □110 | 9/4 - 120 x 20 | 1450 / 1550 | 350 | AX-950 | 410/430 | 350/370 | 180/200 | 120/140 |
| 21 000 | □110 | 10/4 - 120 x 20 | 1450 / 1550 | 350 | AX-950 | 420/440 | 360/380 | 190/210 | 130/150 |
| 21 000 | □110 | 10/5 - 120 x 20 | 1450 / 1550 | 350 | AX-1000 | 420/440 | 360/380 | 190/210 | 130/150 |
| 23 000 | □110 | 11/4 - 120 x 20 | 1550 / 1650 | 370 | AX-1000 | 440/450 | 380/390 | 220/230 | 160/170 |
| 21 000 | □130 | 9/4 - 120 x 20 | 1450 / 1550 | 350 | AX-950 | 420/440 | 360/380 | 190/210 | 130/150 |
| 21 000 | □130 | 10/4 - 120 x 20 | 1450 / 1550 | 350 | AX-950 | 430/450 | 370/390 | 200/220 | 140/160 |
| 21 000 | □130 | 10/5 - 120 x 20 | 1450 / 1550 | 350 | AX-1000 | 430/450 | 370/390 | 200/220 | 140/160 |
| 23 000 | □130 | 11/4 - 120 x 20 | 1550 / 1650 | 370 | AX-1000 | 450/460 | 390/400 | 230/240 | 170/180 |
| 23 000 | □150 | 11/4 - 120 x 20 | 1650 / 1750 | 370 | AX-1000 | 460/470 | 400/410 | 210/220 | 150/160 |

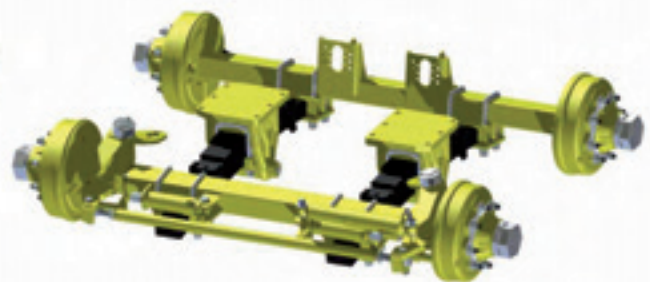
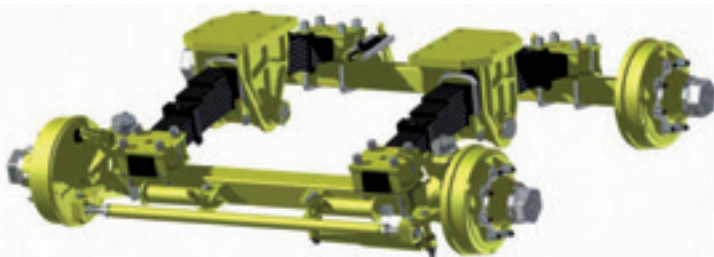



BOGGIES TP
BOGIES PUBLIC WORKS
BOGIES OBRAS PUBLICAS

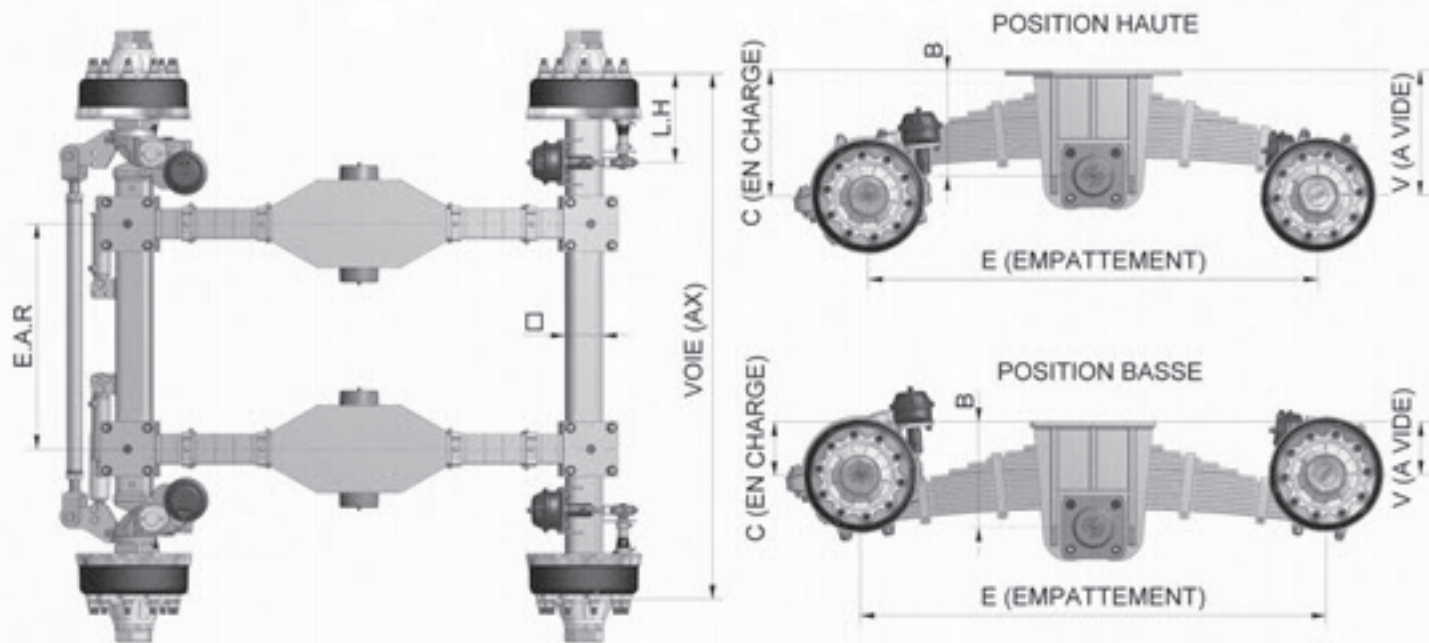

| CHARGE/LOAD /CARGA | CARRE SQUARE CUADADRO | TYPE RESSORT TYPE SPRING BALLESTA | EMPATTEMENT E (mm) | B | E.A.R MAX | POSITION HAUTE | | POSITION BASSE | |
|--|-----------------------------|---|---------------------------|-----|-----------|----------------|---------|----------------|---------|
| | | | | | | V | C | V | C |
| KGS | □ | NB - L x EP. (mm) | | mm | mm | mm | | | |
| 24 000 | □130 FIXE | 11/5 - 120 x 20 | 1550 / 1650 | 420 | AX-600 | 450/460 | 390/400 | 230/240 | 170/180 |
| | □130 GSM3 | 11/5 - 120 x 20 | 1550 / 1650 | 420 | AX-1100 | 450/460 | 390/400 | 230/240 | 170/180 |
| 26 000 | □150 FIXE | 13/5 - 120 x 20 | 1820 | 420 | AX-600 | 495 | 435 | 235 | 175 |
| | □150 GSM2 | 13/5 - 120 x 20 | 1820 | 420 | AX-1100 | 495 | 435 | 235 | 175 |
| VALEUR E.A.R POUR LE FREIN 406x120 CI-DESSUS | | | | | | | | | |
| VALEUR E.A.R POUR LE FREIN 406x140 | | | | | AX-640 | FIXE | AX-1140 | GSM2 | |
| VALEUR E.A.R POUR LE FREIN 420x180 | | | | | AX-720 | FIXE | AX-1220 | GSM2 | |
| VALEUR E.A.R POUR LE FREIN 420x200 | | | | | AX-785 | FIXE | AX-1320 | GSM2 | |

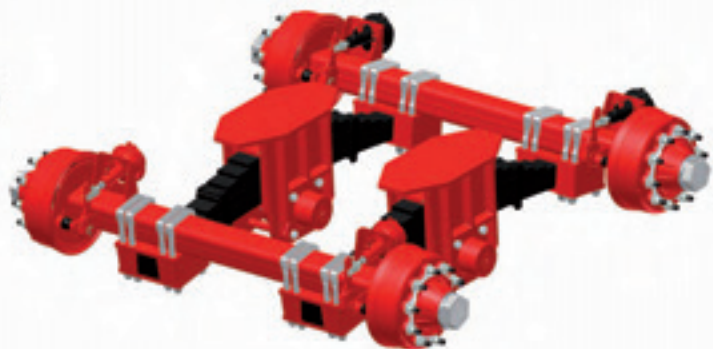
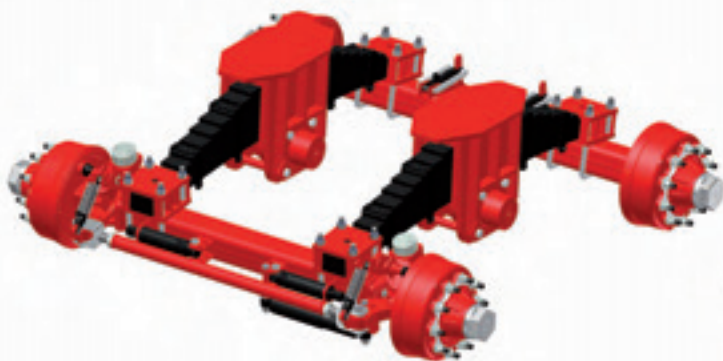



½ TANDEM SIMPLIFIE AVEC RESSORTS MULTILAMES

½ SIMPLIFIED TANDEM WITH MULTI-LEAF SPRINGS

½ TANDEM SIMPLIFICADO CON BALLESTAS MULTIHOJAS



POSITION HAUTE

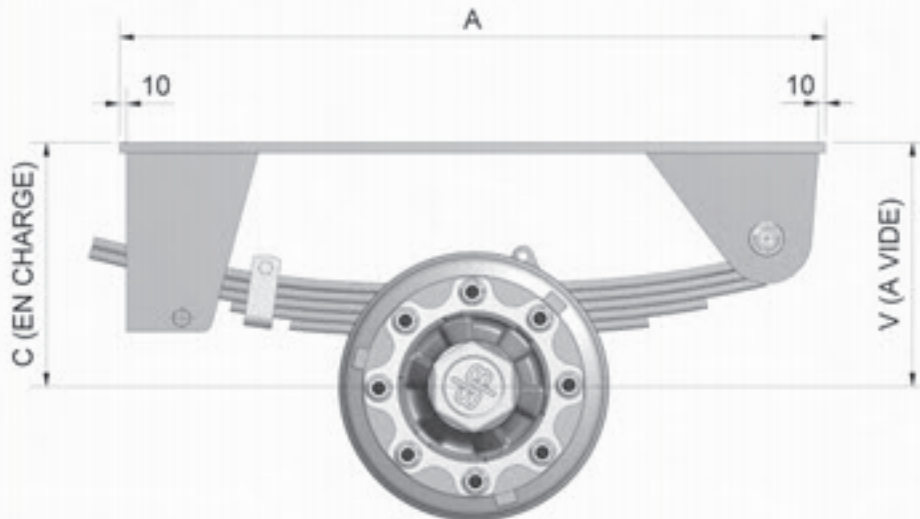

| CHARGE/ LOAD/ CARGA | TYPE RESSORT TYPE SPRING BALLESTA | A | □60 | | □70 | | □80 | | □90 | | □100 | | □110 | | □130 | |
|---------------------------|---|------|-----|-----|-----|-----|-----|-----|-----|-----|------|-----|------|-----|------|-----|
| | | | V | C | V | C | V | C | V | C | V | C | V | C | | |
| KGS | NB - L x EP. (mm) | mm | mm | | | | | | | | | | | | | |
| 4 000 | 4 - 80 x 13 | 810 | 277 | 222 | 282 | 227 | | | | | | | | | | |
| 5 000 | 1-80x15 + 3-80x13 | 910 | | | 284 | 229 | 289 | 234 | | | | | | | | |
| 6 000 | 5 - 80 x 15 | 1010 | | | 305 | 250 | 310 | 255 | 315 | 260 | | | | | | |
| 7 000 | 6 - 80 x 15 | 1160 | | | | | 325 | 270 | 330 | 275 | | | | | | |
| 8 000 | 6 - 100 x 15 | 1060 | | | | | 345 | 305 | 350 | 310 | | | | | | |
| 9 000 | 7 - 100 x 15 | 1100 | | | | | | | 365 | 325 | 370 | 330 | | | | |
| 10 500 | 10 - 100 x 15 | 1100 | | | | | | | | | 415 | 375 | 420 | 380 | 430 | 390 |

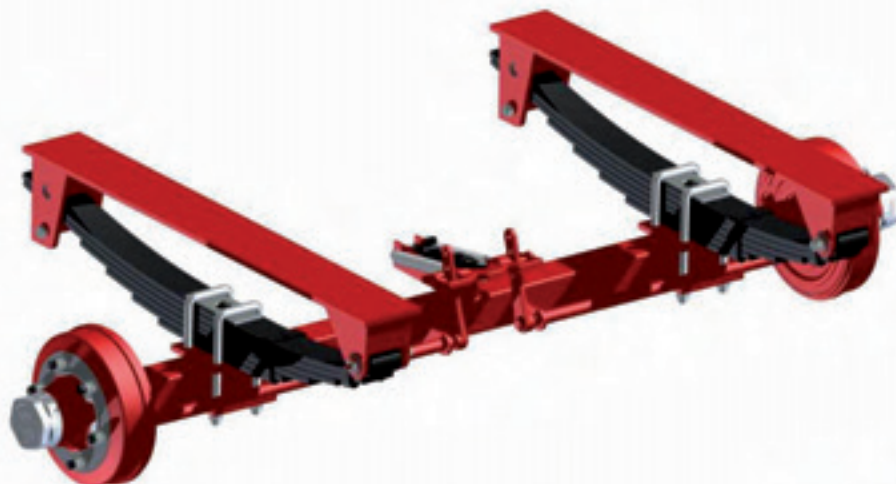

ESSIEUX BOURGOGNE

PAGE 14





½ TANDEM SIMPLIFIE AVEC RESSORTS MULTILAMES

½ SIMPLIFIED TANDEM WITH MULTI-LEAF SPRINGS

½ TANDEM SIMPLIFICADO CON BALLESTAS MULTIHOJAS



POSITION BASSE

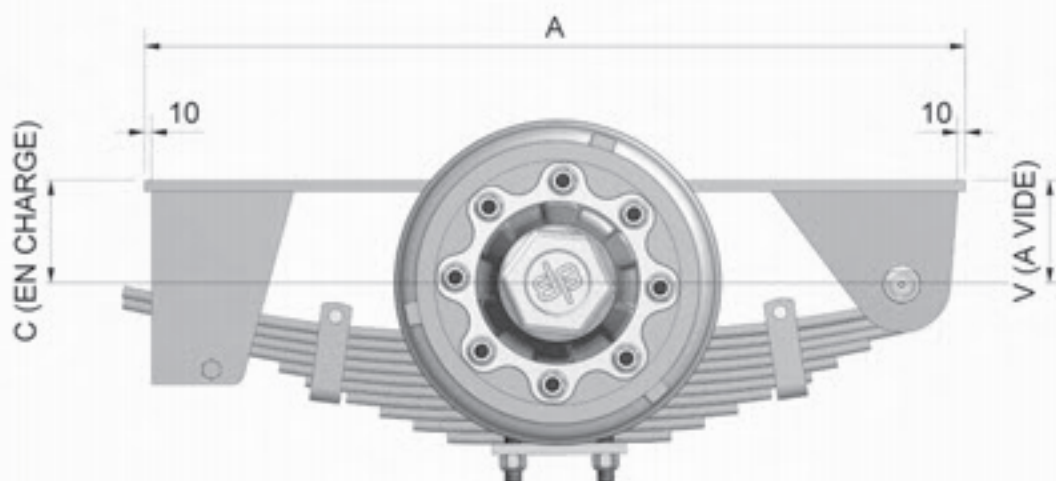

| CHARGE/ LOAD/ CARGA | TYPE RESSORT TYPE SPRING BALLESTA | A | □60 | | □70 | | □80 | | □90 | | □100 | | □110 | | □130 | |
|---------------------------|---|------|-----|----|-----|----|-----|-----|-----|-----|------|-----|------|----|------|----|
| | | | V | C | V | C | V | C | V | C | V | C | V | C | | |
| KGS | NB – L x EP. (mm) | mm | mm | | | | | | | | | | | | | |
| 4 000 | 4 – 80 x 13 | 810 | 140 | 85 | 135 | 80 | / | / | / | / | / | / | / | / | / | / |
| 5 000 | 1-80x15 + 3-80x13 | 910 | / | / | 135 | 80 | 130 | 75 | / | / | / | / | / | / | / | |
| 6 000 | 5 – 80 x 15 | 1010 | / | / | 135 | 80 | 130 | 75 | 125 | 70 | / | / | / | / | | |
| 7 000 | 6 – 80 x 15 | 1160 | / | / | / | / | 130 | 75 | 125 | 70 | / | / | / | / | | |
| 8 000 | 6 – 100 x 15 | 1060 | / | / | / | / | 150 | 110 | 145 | 105 | / | / | / | / | | |
| 9 000 | 7 – 100 x 15 | 1100 | / | / | / | / | / | / | 145 | 105 | 140 | 100 | / | / | | |
| 10 500 | 10 – 100 x 15 | 1100 | / | / | / | / | / | / | 145 | 105 | 140 | 100 | 135 | 95 | 125 | 85 |

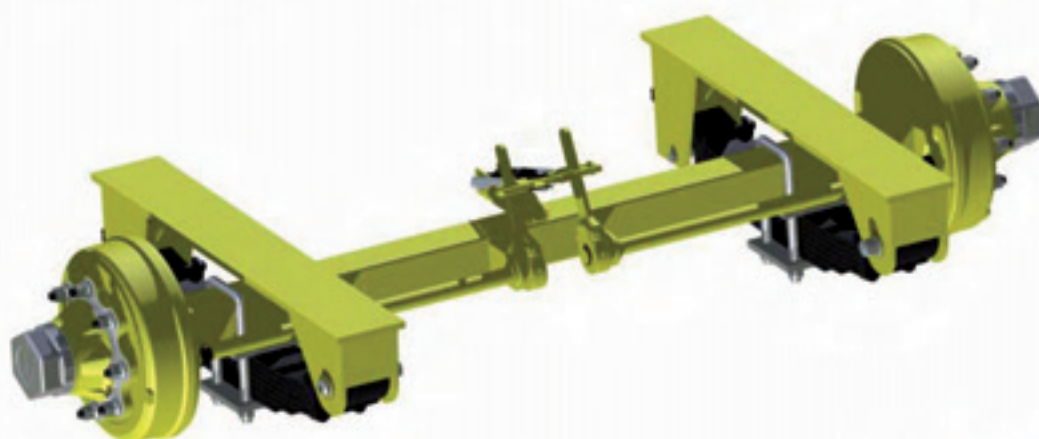



½ TANDEMS SIMPLIFIE AVEC RESSORTS PARABOLIQUES

½ SIMPLIFIED TANDEMS WITH PARABOLIC SPRINGS

½ TANDEMS SIMPLIFICADO CON BALLESTAS PARABOLICAS



POSITION HAUTE

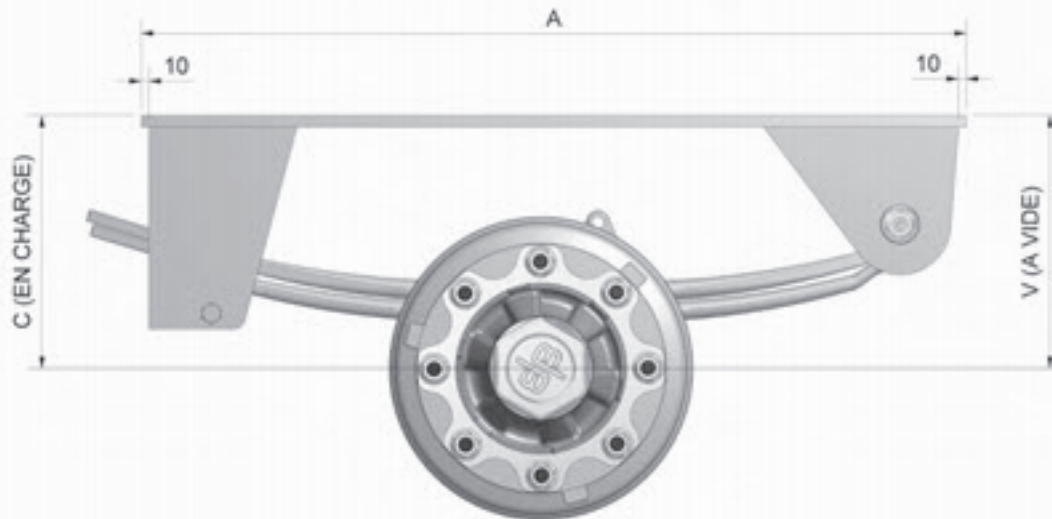

| CHARGE/ LOAD/ CARGA | TYPE RESSORT TYPE SPRING BALLESTA | A | □90 | | □100 | | □110 | | □130 | |
|---------------------------|---|------|-----|-----|------|-----|------|-----|------|-----|
| | | | V | C | V | C | V | C | V | C |
| KGS | NB – L x EP. (mm) | mm | mm | | | | | | | |
| 9 000 | 2 – 100 x 25 | 1100 | 325 | 270 | 330 | 275 | | | | |
| 10 500 | 2 – 100 x 25 | 1100 | | | 330 | 275 | 335 | 280 | 345 | 290 |

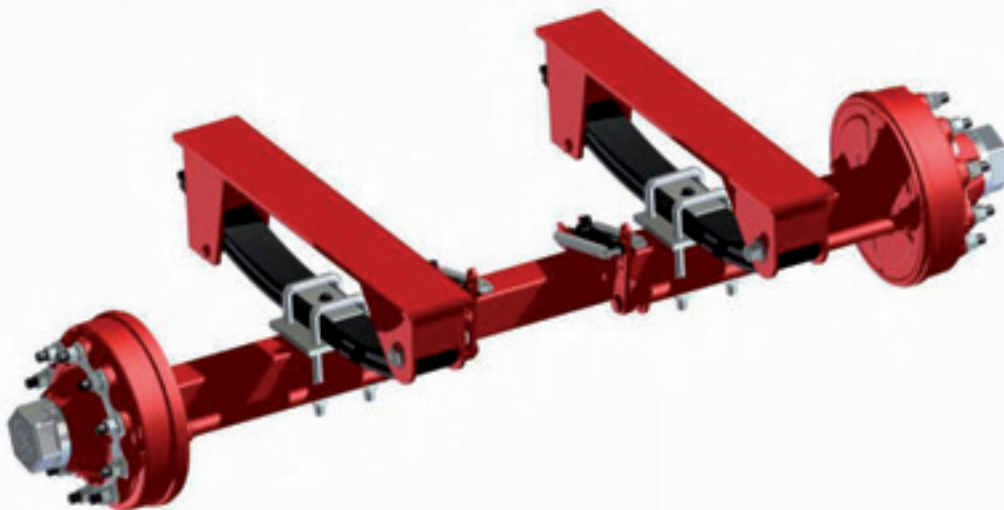



TANDEMS SIMPLIFIE AVEC RESSORTS MULTILAMES

SIMPLIFIED TANDEMS WITH MULTI-LEAF SPRINGS

TANDEMS SIMPLIFICADO CON BALLESTAS MULTIHOJAS



POSITION HAUTE

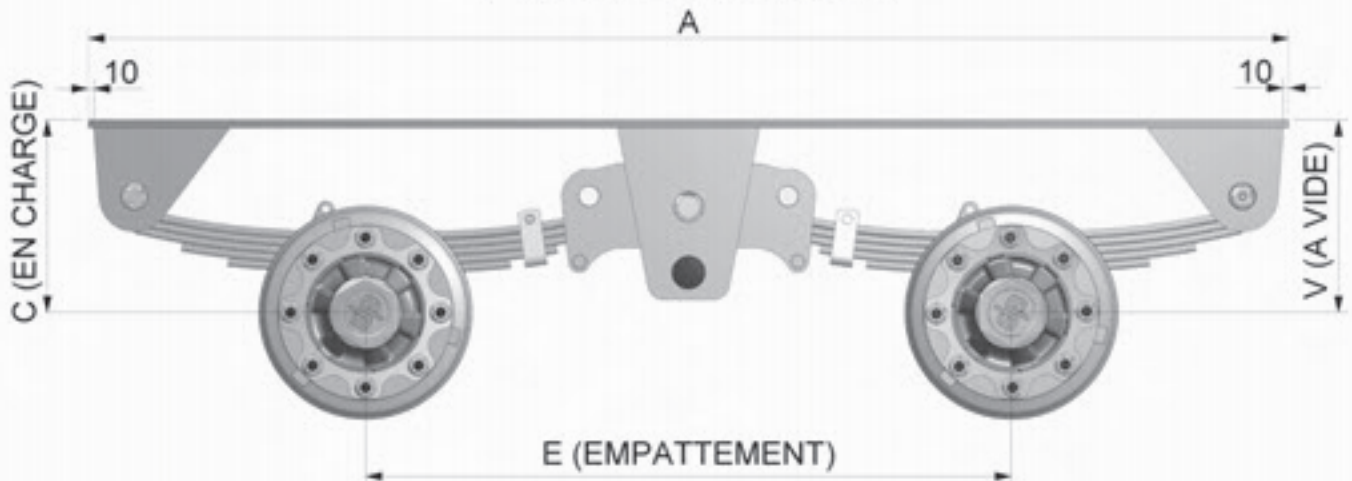

| CHARGE/ LOAD/ CARGA | TYPE RESSORT TYPE SPRING BALLESTA | E | A | □60 | | □70 | | □80 | | □90 | | □100 | | □110 | | □130 | | |
|---------------------------|---|------|------|-----|-----|-----|-----|-----|-----|-----|-----|------|-----|------|-----|------|-----|---|
| | | | | V | C | V | C | V | C | V | C | V | C | V | C | | | |
| KGS | NB - L x EP. (mm) | mm | mm | mm | | | | | | | | | | | | | | |
| 8 000 | 4 - 80 x 13 | 1000 | 1780 | 277 | 222 | 282 | 227 | / | / | / | / | / | / | / | / | / | / | / |
| 10 000 | 1-80x15 + 3-80x13 | 1100 | 1980 | / | / | 284 | 229 | 289 | 234 | / | / | / | / | / | / | / | / | / |
| 12 000 | 5 - 80 x 15 | 1200 | 2180 | / | / | 305 | 250 | 310 | 255 | 315 | 260 | / | / | / | / | / | / | / |
| 14 000 | 6 - 80 x 15 | 1380 | 2490 | / | / | / | / | 325 | 270 | 330 | 275 | / | / | / | / | / | / | / |
| 16 000 | 6 - 100 x 15 | 1200 | 2200 | / | / | / | / | 350 | 310 | 355 | 315 | 360 | 320 | / | / | / | / | / |
| 18 000 | 7 - 100 x 15 | 1380 | 2460 | / | / | / | / | / | / | 370 | 330 | 375 | 335 | 380 | 340 | 390 | 350 | |
| | | 1450 | 2530 | / | / | / | / | / | / | / | / | / | / | / | / | / | / | / |
| 21 000 | 10 - 100 x 15 | 1380 | 2460 | / | / | / | / | / | / | / | / | 415 | 375 | 420 | 380 | 430 | 390 | |
| | | 1450 | 2530 | / | / | / | / | / | / | / | / | / | / | / | / | / | / | / |
| 23 000 | 10 - 100 x 15 | 1520 | 2580 | / | / | / | / | / | / | / | / | / | / | 420 | 380 | 430 | 390 | |
| | | 1600 | 2680 | / | / | / | / | / | / | / | / | / | / | / | / | / | / | / |

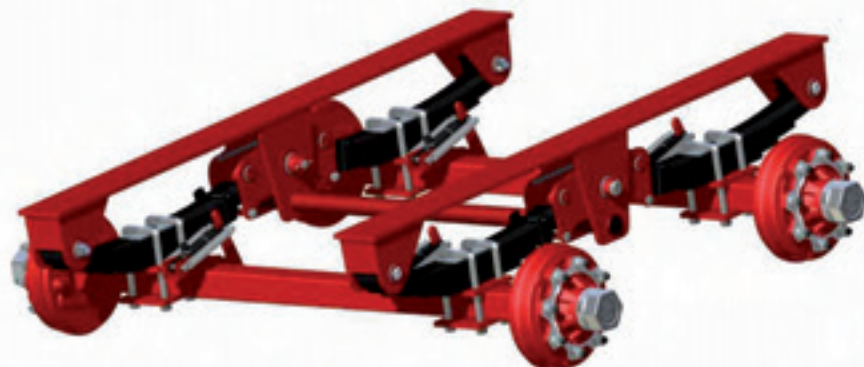

ESSIEUX BOURGOGNE

PAGE 17

AMB



TANDEMS SIMPLIFIE AVEC RESSORTS MULTILAMES
 SIMPLIFIED TANDEMS WITH MULTI-LEAF SPRINGS
 TANDEMS SIMPLIFICADO CON BALLESTAS MULTIHOJAS



POSITION BASSE

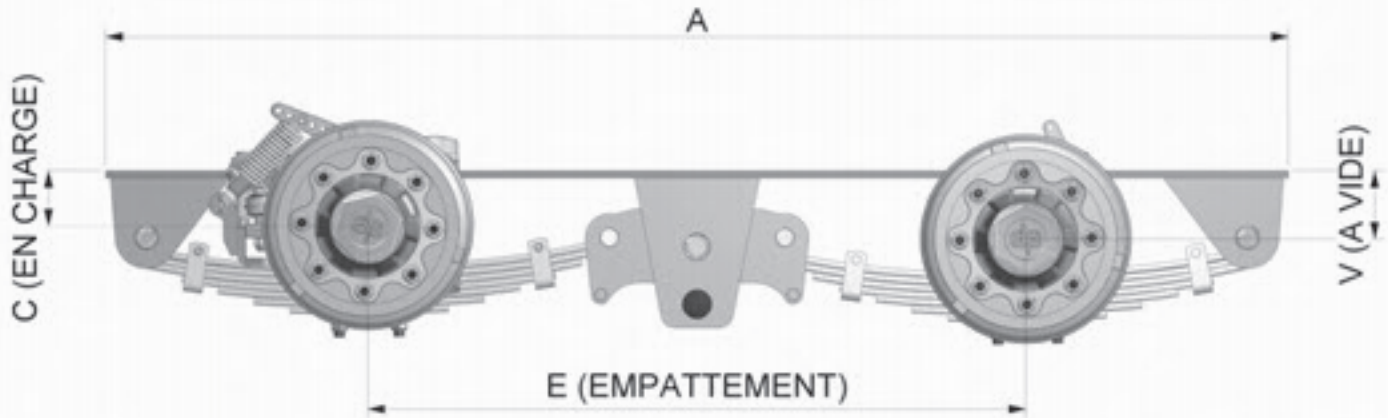

| CHARGE/ LOAD/ CARGA | TYPE RESSORT TYPE SPRING BALLESTA | E | A | □60 | | □70 | | □80 | | □90 | | □100 | | □110 | | □130 | | | |
|---------------------------|---|------|------|-----|----|-----|----|-----|-----|-----|-----|------|-----|------|----|------|----|---|--|
| | | | | V | C | V | C | V | C | V | C | V | C | V | C | | | | |
| KGS | NB – L x EP. (mm) | mm | mm | mm | | | | | | | | | | | | | | | |
| 8 000 | 4 – 80 x 13 | 1000 | 1780 | 140 | 85 | 135 | 80 | / | / | / | / | / | / | / | / | / | / | / | |
| 10 000 | 1-80x15 + 3-80x13 | 1100 | 1980 | / | / | 135 | 80 | 130 | 75 | / | / | / | / | / | / | / | / | / | |
| 12 000 | 5 – 80 x 15 | 1200 | 2180 | / | / | 135 | 80 | 130 | 75 | 125 | 70 | / | / | / | / | / | / | / | |
| 14 000 | 6 – 80 x 15 | 1380 | 2490 | / | / | / | / | 130 | 75 | 125 | 70 | / | / | / | / | / | / | / | |
| 16 000 | 6 – 100 x 15 | 1200 | 2200 | / | / | / | / | 150 | 110 | 145 | 105 | 140 | 100 | / | / | / | / | / | |
| 18 000 | 7 – 100 x 15 | 1380 | 2460 | / | / | / | / | / | / | 145 | 105 | 140 | 100 | / | / | / | / | / | |
| | | 1450 | 2530 | / | / | / | / | / | / | / | / | / | / | / | / | / | / | / | |
| 21 000 | 10 – 100 x 15 | 1380 | 2460 | / | / | / | / | / | / | / | / | 140 | 100 | 135 | 95 | 125 | 85 | / | |
| | | 1450 | 2530 | / | / | / | / | / | / | / | / | / | / | / | / | / | / | / | |
| 23 000 | 10 – 100 x 15 | 1520 | 2600 | / | / | / | / | / | / | / | / | / | / | 135 | 95 | 125 | 85 | / | |
| | | 1600 | 2680 | / | / | / | / | / | / | / | / | / | / | / | / | / | / | / | |

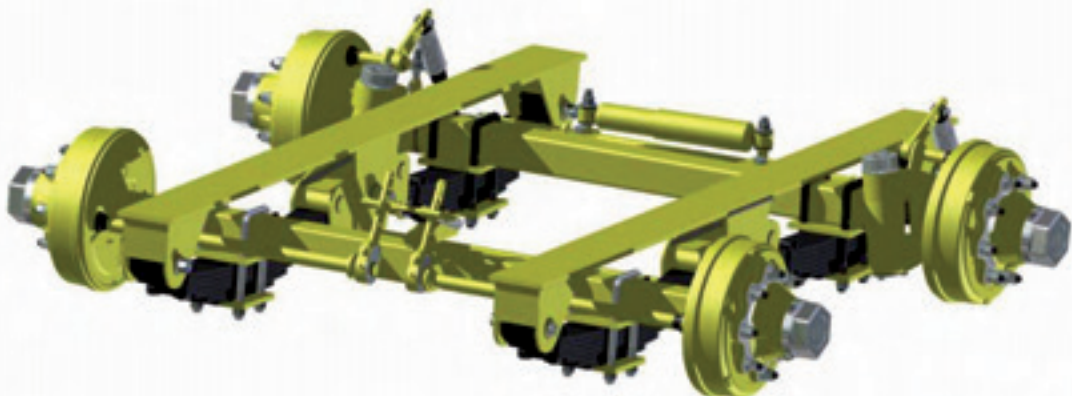



TANDEMS SIMPLIFIE AVEC RESSORTS PARABOLIQUES

SIMPLIFIED TANDEMS WITH PARABOLIC SPRINGS

TANDEMS SIMPLIFICADO CON BALLESTAS PARABOLICAS

POSITION HAUTE

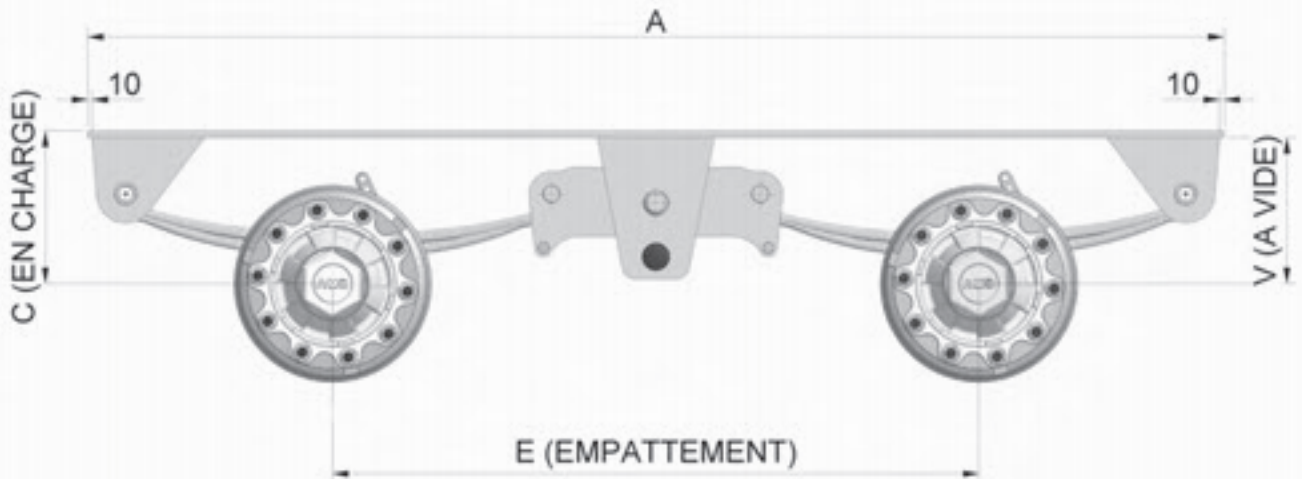

| CHARGE/ LOAD/ CARGA | TYPE RESSORT TYPE SPRING BALLESTA | E | A | □90 | | □100 | | □110 | | □130 | |
|---------------------------|---|------|------|-----|-----|------|-----|------|-----|------|-----|
| | | | | V | C | V | C | V | C | V | C |
| KGS | NB - L x EP. (mm) | mm | mm | mm | | | | | | | |
| 16 000 | 2 - 100 x 25 | 1380 | 2460 | 325 | 270 | 330 | 275 | | | | |
| 18 000 | 2 - 100 x 25 | 1450 | 2530 | | | 330 | 275 | 335 | 280 | 345 | 290 |
| 21 000 | 2 - 100 x 25 | 1520 | 2600 | | | 330 | 275 | 335 | 280 | 345 | 290 |
| 23 000 | 2 - 100 x 25 | 1600 | 2680 | | | | | 335 | 280 | 345 | 290 |

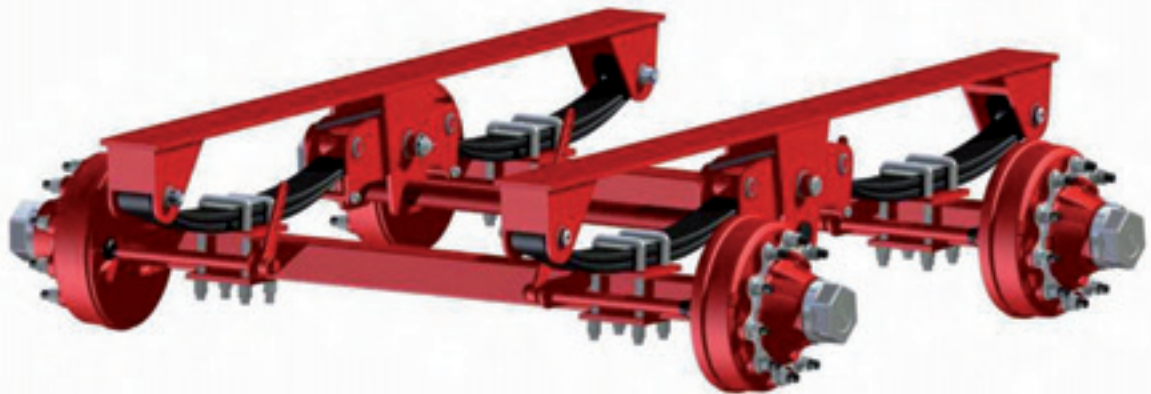



½ TANDEMS A BIELLE AVEC RESSORTS MULTILAMES

½ TANDEMS WITH TIE ROD AND MULTI-LEAF SPRINGS

½ TANDEMS CON BIELAS Y BALLESTAS MULTIHOJAS



POSITION HAUTE

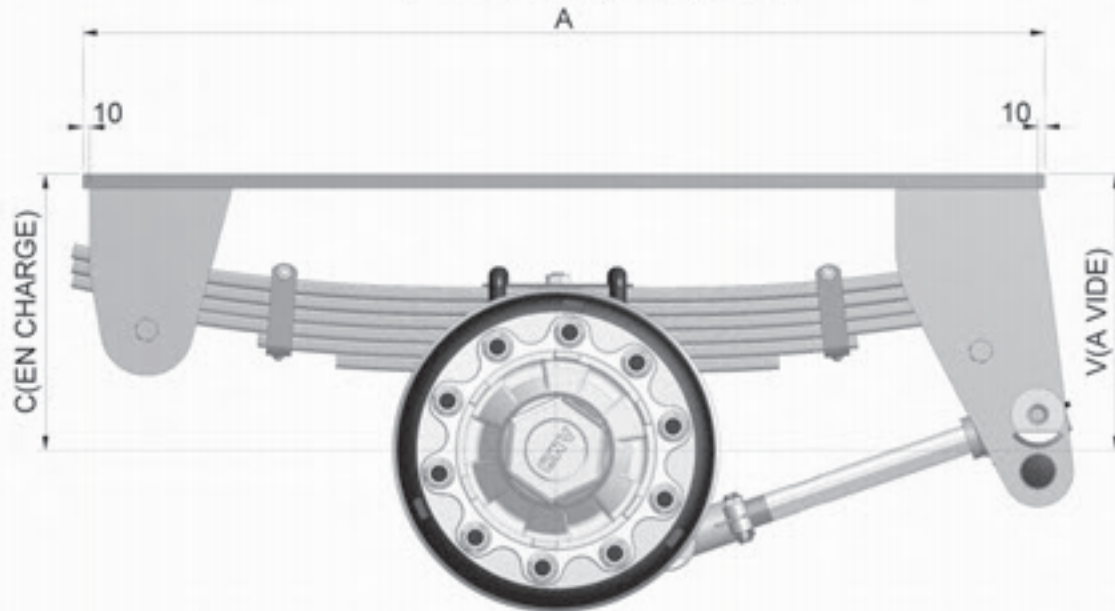

| CHARGE/LOAD/CARGA | TYPE RESSORT TYPE SPRING BALLESTA | A | □90 | | □100 | | □110 | | □130 | | □150 | |
|-------------------|---|------|-----|-----|------|-----|------|-----|------|-----|------|-----|
| | | | V | C | V | C | V | C | V | C | V | C |
| KGS | NB – L x EP. (mm) | mm | mm | | | | | | | | | |
| 9 000 | 6/3 – 100 x 20 | 1150 | 345 | 305 | 350 | 310 | 355 | 315 | | | | |
| | 7/3 – 100 x 20 | 1250 | 365 | 325 | 370 | 330 | 375 | 335 | | | | |
| 11 000 | 7/3 – 100 x 20 | 1250 | | | 370 | 330 | 375 | 335 | 385 | 345 | | |
| | 7/3 – 100 x 20 | 1350 | | | 370 | 330 | 375 | 335 | 390 | 350 | | |
| 13 000 | 7/3 – 100 x 20 | 1350 | | | | | 375 | 335 | 390 | 350 | 395 | 355 |
| | 8/4 – 100 x 20 | 1470 | | | | | 395 | 355 | 410 | 370 | 415 | 375 |

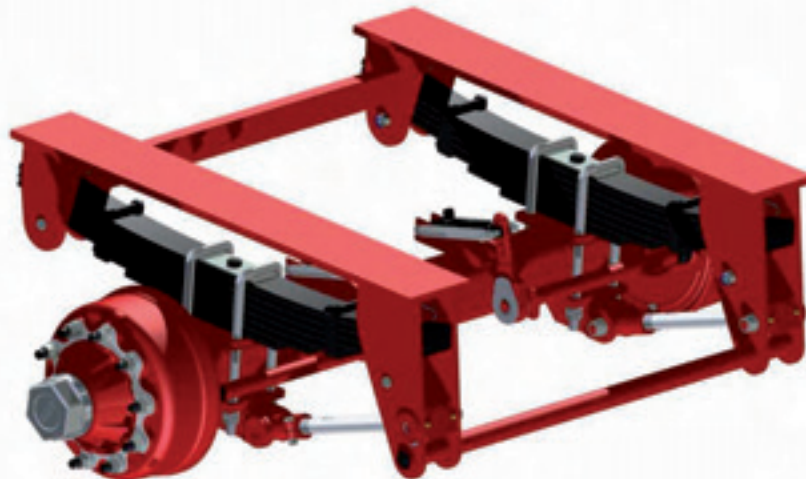



½ TANDEMS A BIELLE AVEC RESSORTS MULTILAMES

½ TANDEM WITH TIE ROD AND MULTI-LEAF SPRINGS

½ TANDEM CON BIELAS Y BALLESTAS MULTIHOJAS



POSITION BASSE

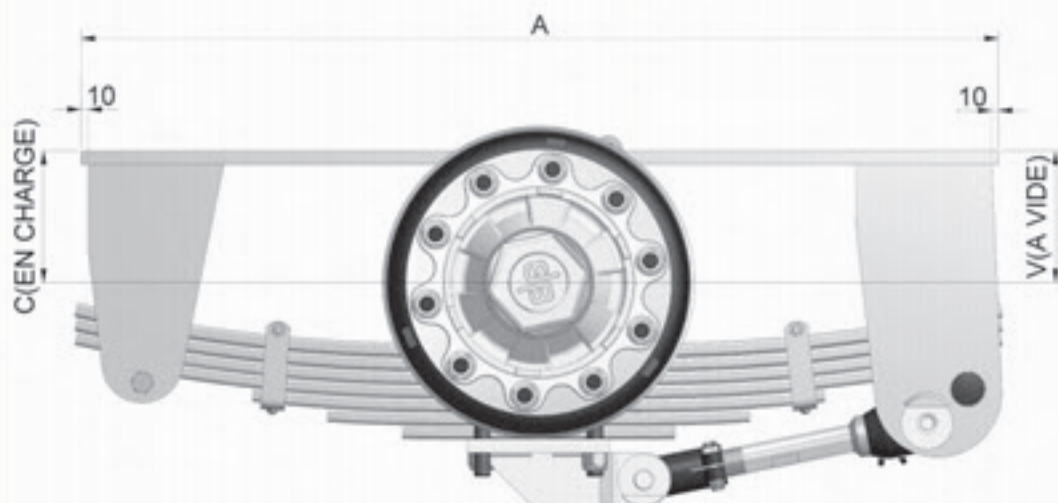

| CHARGE/LOAD/CARGA | TYPE RESSORT TYPE SPRING BALLESTA | A | □110 | | □130 | | □150 | |
|-------------------|---|------|------|-----|------|-----|------|-----|
| | | | V | C | V | C | V | C |
| KGS | NB – L x EP.(mm) | mm | mm | | | | | |
| 11 000 | 7/3 – 100 x 20 | 1350 | 208 | 168 | | | | |
| 13 000 | 7/3 – 100 x 20 | 1350 | 208 | 168 | 198 | 158 | 188 | 148 |
| | 8/4 – 100 x 20 | 1470 | 208 | 168 | 198 | 158 | 188 | 148 |

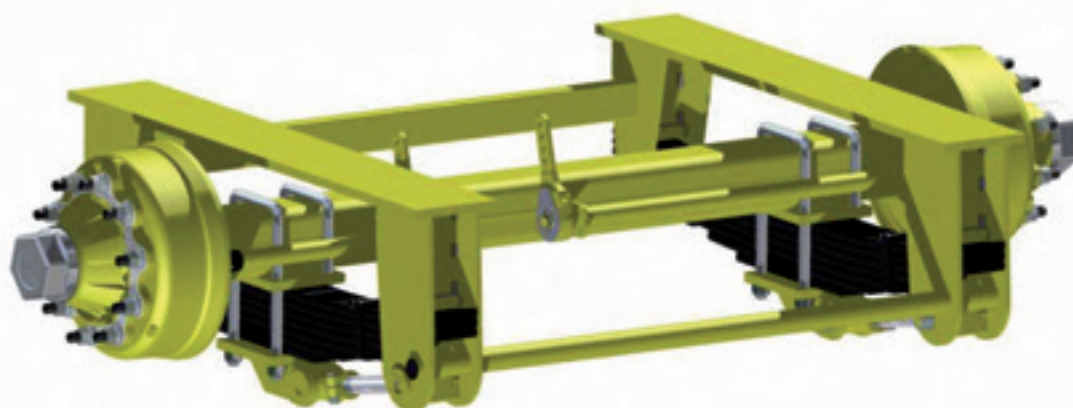



½ TANDEMS A BIELLE AVEC RESSORTS PARABOLIQUES

½ TANDEMS WITH TIE ROD AND PARABOLIC SPRING

½ TANDEMS CON BIELAS Y BALLESTAS PARABOLICAS



POSITION HAUTE

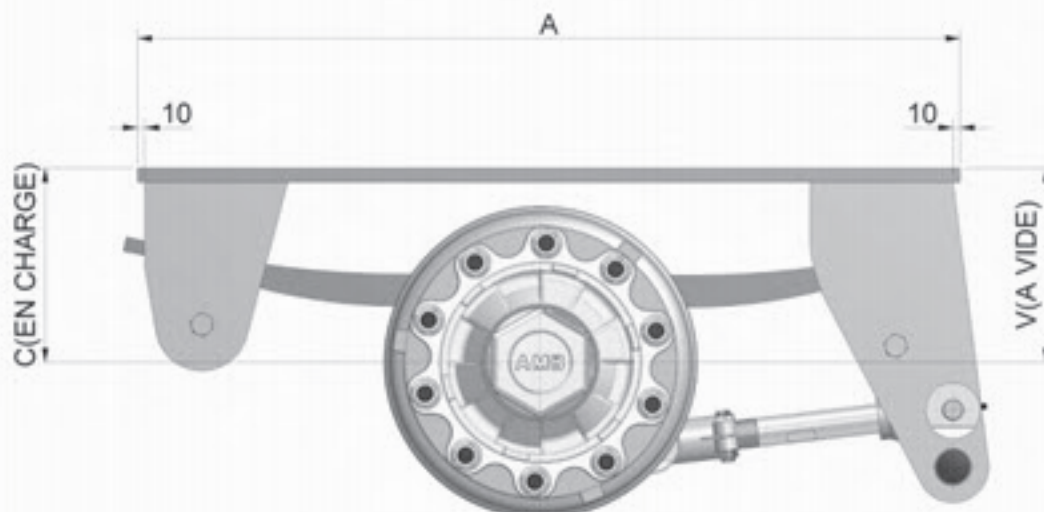

| CHARGE/LOAD/CARGA | TYPE RESSORT TYPE SPRING BALLESTA | A | □90 | | □100 | | □110 | | □130 | |
|-------------------|---|------|-----|-----|------|-----|------|-----|------|-----|
| | | | V | C | V | C | V | C | V | C |
| KGS | NB – L x EP. (mm) | mm | mm | | | | | | | |
| 8 000 | 1 – 100 x 45 | 1150 | 263 | 233 | / | / | / | / | / | / |
| | 3 – 100 x 24 | 1130 | 321 | 281 | / | / | / | / | / | / |
| 9 000 | 1 – 100 x 45 | 1150 | / | / | 268 | 238 | 273 | 243 | / | / |
| | 3 – 100 x 24 | 1130 | / | / | 326 | 286 | 331 | 291 | / | / |
| 11 000 | 1 – 100 x 45 | 1150 | / | / | / | / | 273 | 243 | 283 | 258 |
| | 3 – 100 x 27 | 1230 | / | / | / | / | 345 | 305 | 360 | 320 |

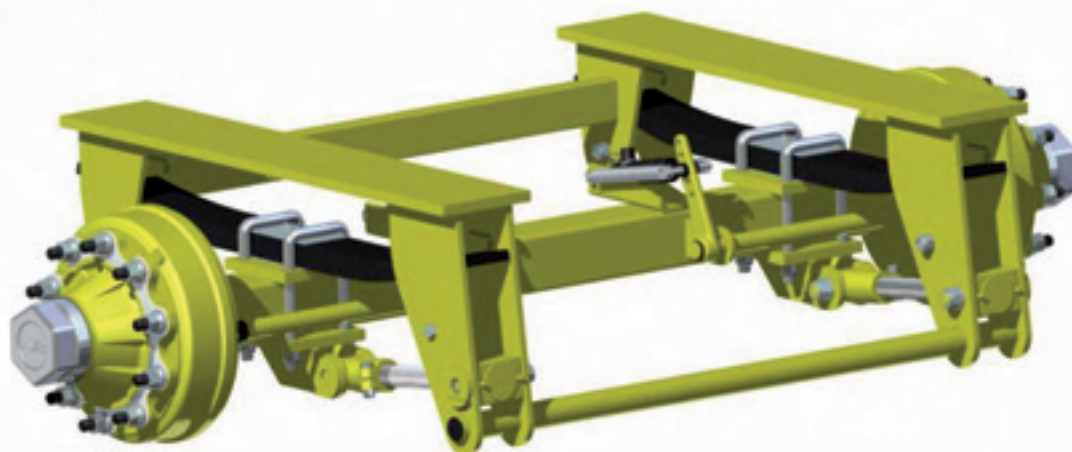



TANDEMS A BIELLES AVEC RESSORTS MULTILAMES
 TANDEMS WITH TIE ROD AND MULTI-LEAF SPRINGS
 TANDEMS CON BIELAS Y BALLESTAS MULTIHOJAS



POSITION HAUTE

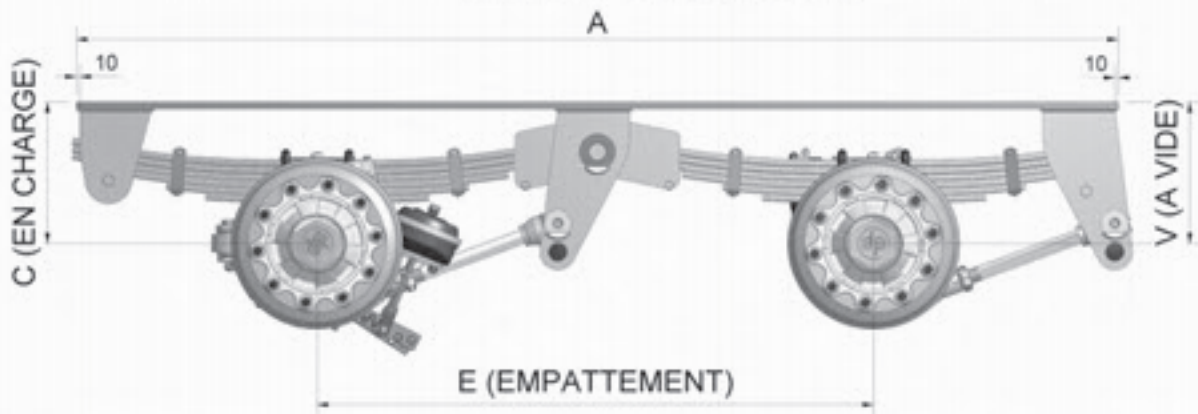

| CHARGE/LOAD /CARGA | EMPATTEMENT E (mm) | TYPE RESSORT TYPE SPRING BALLESTA NB - L x EP. (mm) | A mm | □90 | | □100 | | □110 | | □130 | | □150 | |
|-----------------------|-----------------------|--|-------------|-----|-----|------|-----|------|-----|------|-----|------|-----|
| | | | | V | C | V | C | V | C | V | C | | |
| KGS | | | | mm | | | | | | | | | |
| 16 000 | 1350 / 1500 | 6/3 - 100 x 20 | 2500 / 2670 | 345 | 305 | 350 | 310 | 355 | 315 | | | | |
| | 1450 / 1600 | 7/3 - 100 x 20 | 2700 / 2850 | 365 | 325 | 370 | 330 | 375 | 335 | | | | |
| 18 000 | 1350 / 1500 | 6/3 - 100 x 20 | 2500 / 2670 | | | 350 | 310 | 355 | 315 | 365 | 325 | 375 | 335 |
| | 1450 / 1600 | 7/3 - 100 x 20 | 2700 / 2850 | | | 370 | 330 | 375 | 335 | 385 | 345 | 395 | 355 |
| | 1550 / 1700 | 7/3 - 100 x 20 | 2900 / 3050 | | | 370 | 330 | 375 | 335 | 385 | 345 | 395 | 355 |
| | | 7/3 - 100 x 20 P | 2900 / 3050 | | | 330 | 290 | 335 | 295 | 345 | 305 | 355 | 315 |
| 21000 | 1450 / 1600 | 7/3 - 100 x 20 | 2700 / 2850 | | | 370 | 330 | 375 | 335 | 385 | 345 | 395 | 355 |
| | 1550 / 1700 | 7/3 - 100 x 20 | 2900 / 3050 | | | 370 | 330 | 375 | 335 | 385 | 345 | 395 | 355 |
| | | 7/3 - 100 x 20 P | 2900 / 3050 | | | 330 | 290 | 335 | 295 | 345 | 305 | 355 | 315 |
| 24000 | 1450 / 1600 | 7/3 - 100 x 20 | 2700 / 2850 | | | | | 375 | 335 | 385 | 345 | 395 | 355 |
| | 1550 / 1700 | 7/3 - 100 x 20 | 2900 / 3050 | | | | | 375 | 335 | 385 | 345 | 395 | 355 |
| | | 7/3 - 100 x 20 P | 2900 / 3050 | | | | | | 335 | 295 | 345 | 315 | 355 |
| 26 000 | 1670 / 1820 | 8/4 - 100 x 20 | 3140 / 3290 | | | | | 400 | 360 | 410 | 370 | 420 | 380 |
| | | 8/4 - 100 x 20 P | 3140 / 3290 | | | | | | | | | 375 | 335 |

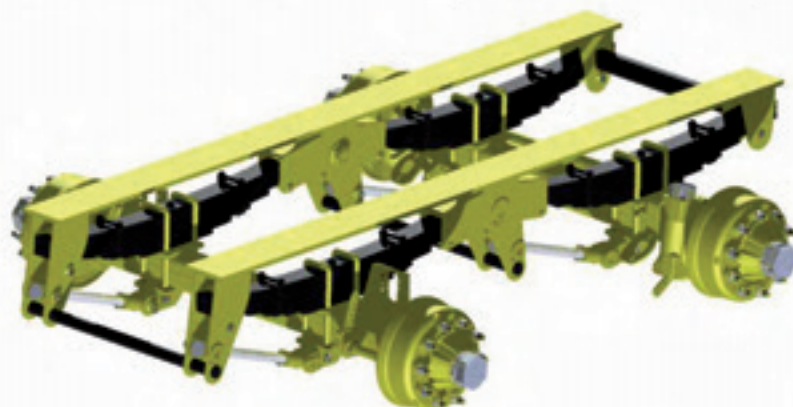



TANDEMS A BIELLES AVEC RESSORTS MULTILAMES
 TANDEMS WITH TIE ROD AND MULTI-LEAF SPRINGS
 TANDEMS CON BIELAS Y BALLESTAS MULTIHOJAS



POSITION BASSE

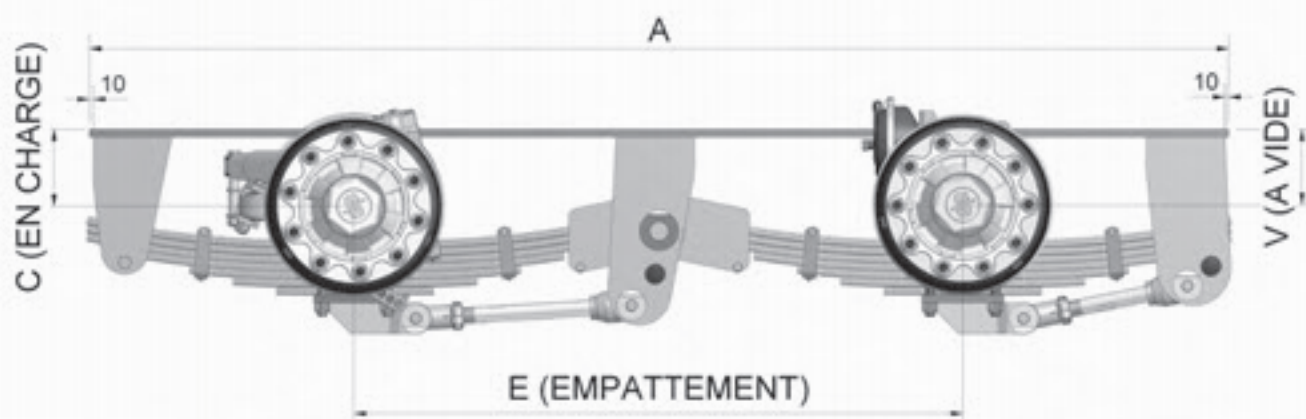

| CHARGE/LOAD/CARGA | EMPATTEMENT E (mm) | TYPE RESSORT TYPE SPRING BALLESTA NB - L x EP. (mm) | A mm | □90 | | □100 | | □110 | | □130 | | □150 | |
|-------------------|-----------------------|--|-------------|-----|-----|------|-----|------|-----|------|-----|------|-----|
| | | | | V | C | V | C | V | C | V | C | V | C |
| KGS | | | | mm | | | | | | | | | |
| 18 000 | 1550 / 1700 | 7/3 - 100 x 20 | 2900 / 3050 | 218 | 178 | 213 | 173 | 208 | 168 | 198 | 158 | 188 | 148 |
| 21 000 | 1550 / 1700 | 7/3 - 100 x 20 | 2900 / 3050 | | | 213 | 173 | 208 | 168 | 198 | 158 | 188 | 148 |
| 24 000 | 1550 / 1700 | 7/3 - 100 x 20 | 2900 / 3050 | | | | | 208 | 168 | 198 | 158 | 188 | 148 |
| 26 000 | 1670 / 1820 | 8/4 - 100 x 20 P | 3140 / 3290 | | | | | 208 | 168 | 198 | 158 | 188 | 148 |

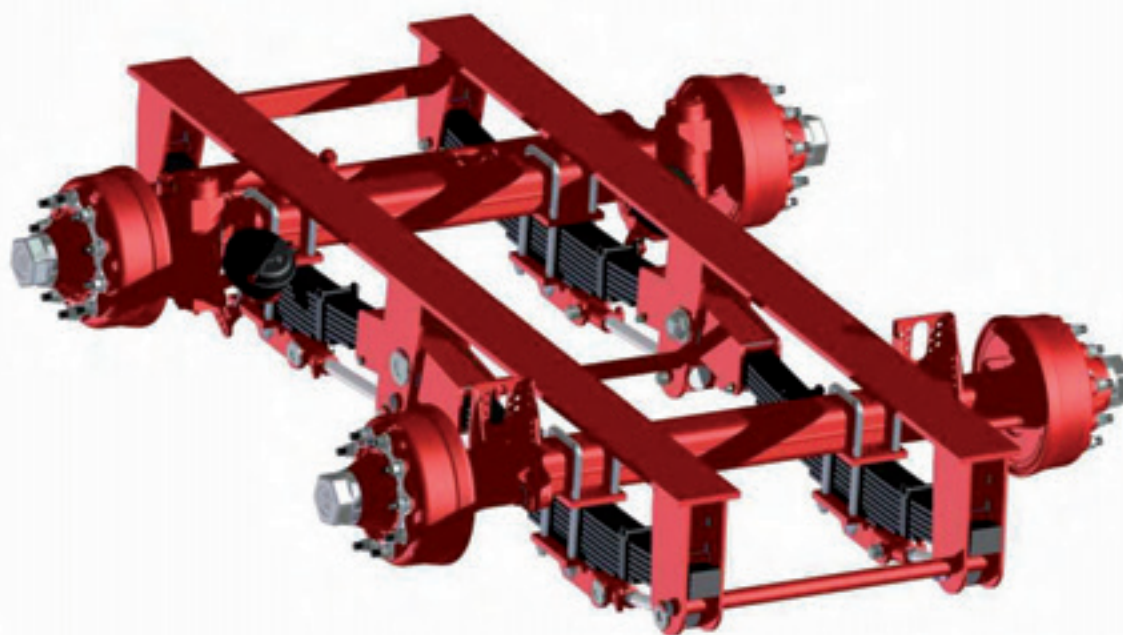



TANDEMS A BIELLES AVEC RESSORTS PARABOLIQUES
 TANDEMS WITH TIE ROD AND PARABOLIC SPRINGS
 TANDEMS CON BIELAS Y BALLESTAS PARABOLICAS



POSITION HAUTE

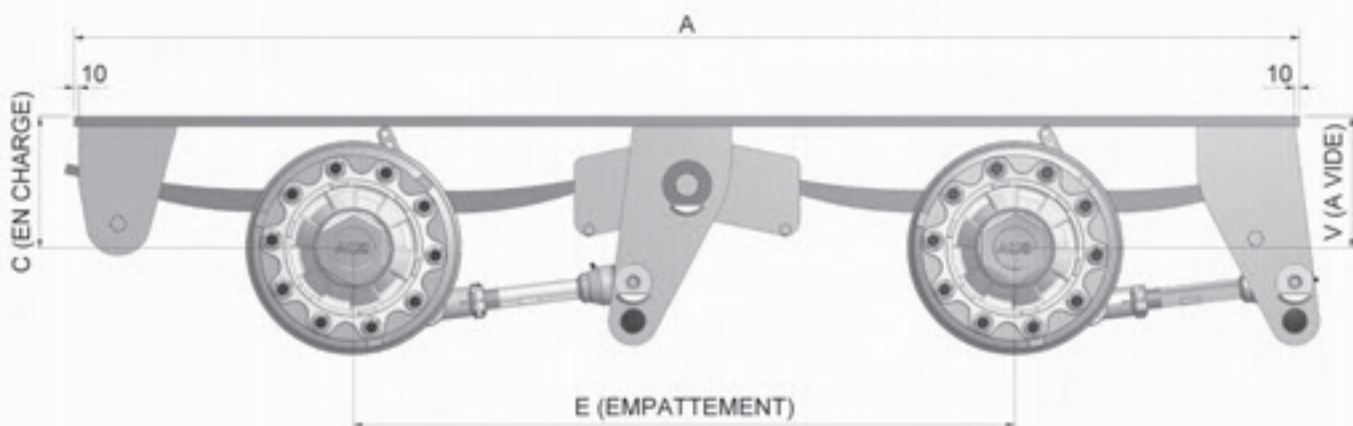

| CHARGE/LOAD/CARGA | EMPATTEMENT E (mm) | TYPE RESSORT TYPE SPRING BALLESTA NB - L x EP. (mm) | A mm | □90 | | □100 | | □110 | | □130 | |
|-------------------|-----------------------|--|-------------|-----|-----|------|-----|------|-----|------|-----|
| | | | | V | C | V | C | V | C | V | C |
| KGS | | | | mm | | | | | | | |
| 16 000 | 1350 / 1500 | 1 - 100 x 45 | 2500 / 2670 | 263 | 233 | | | | | | |
| | 1350 / 1500 | 3 - 100 x 24 | 2500 / 2670 | 321 | 281 | | | | | | |
| 18 000 | 1350 / 1500 | 1 - 100 x 45 | 2500 / 2670 | | | 268 | 238 | 273 | 243 | | |
| | 1350 / 1500 | 3 - 100 x 24 | 2500 / 2670 | | | 326 | 286 | 331 | 291 | | |
| 21 000 | 1350 / 1500 | 1 - 100 x 45 | 2500 / 2670 | | | | | 273 | 243 | 283 | 253 |
| | 1450 / 1600 | 3 - 100 x 27 | 2700 / 2850 | | | | | 345 | 305 | 355 | 315 |

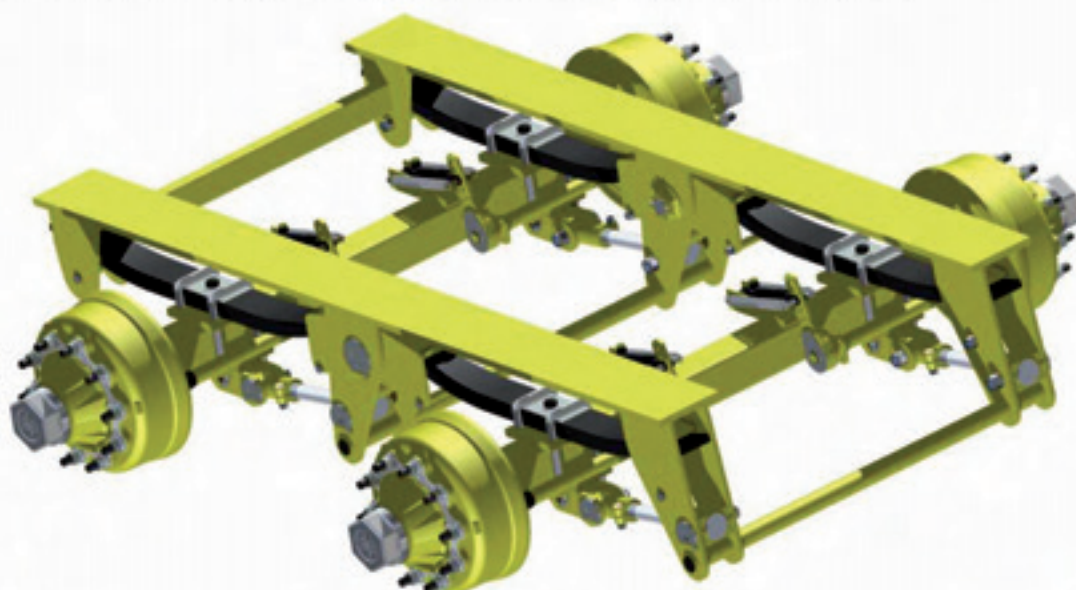



TRIDEMS A BIELLES AVEC RESSORTS MULTILAMES
TRIDEMS WITH TIE ROD AND MULTI-LEAF SPRINGS
TRIDEMS CON BIELAS Y BALLESTAS MULTIHOJAS



POSITION HAUTE

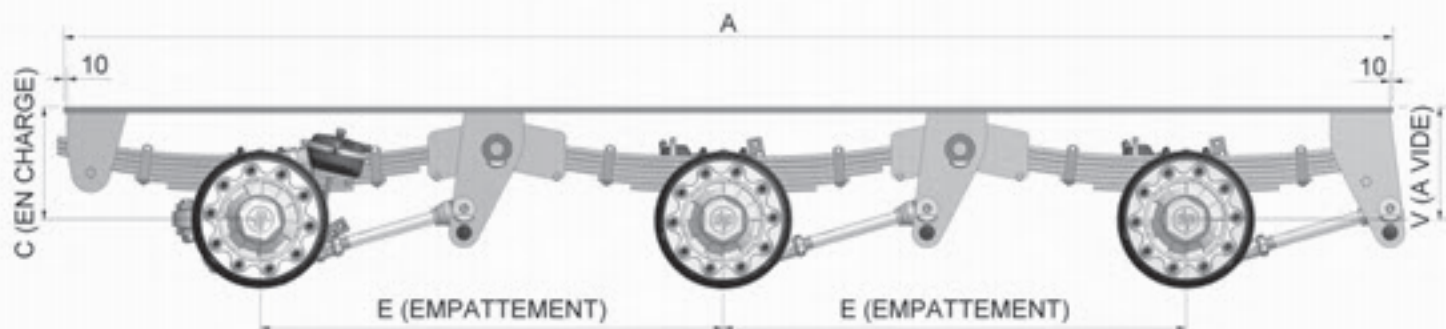

| CHARGE/LOAD/CARGA | EMPATTEMENT E (mm) | TYPE RESSORT TYPE SPRING BALLESTA NB - L x EP. (mm) | A mm | □100 | | □110 | | □130 | | □150 | |
|-------------------|-----------------------|--|-------------|------|-----|------|-----|------|-----|------|-----|
| | | | | V | C | V | C | V | C | V | C |
| KGS | | | | mm | | | | | | | |
| 24 000 | 1350 / 1500 | 6/3 - 100 x 20 | 3850 / 4150 | 350 | 310 | | | | | | |
| | 1450 / 1600 | 7/3 - 100 x 20 | 4150 / 4450 | 370 | 330 | | | | | | |
| 30 000 | 1350 / 1500 | 6/3 - 100 x 20 | 3850 / 4150 | | | 355 | 315 | 365 | 325 | | |
| | 1450 / 1600 | 7/3 - 100 x 20 | 4150 / 4450 | | | 375 | 335 | 385 | 345 | | |
| | 1550 / 1700 | 7/3 - 100 x 20 | 4450 / 4750 | 370 | 330 | 375 | 335 | 385 | 345 | | |
| 32 000 | 1670 / 1820 | 8/4 - 100 x 20 | 4810 / 5110 | | | 395 | 355 | 405 | 365 | | |
| | 1670 / 1820 | 8/4 - 100 x 20 | 4810 / 5110 | | | | | 405 | 365 | 425 | 385 |

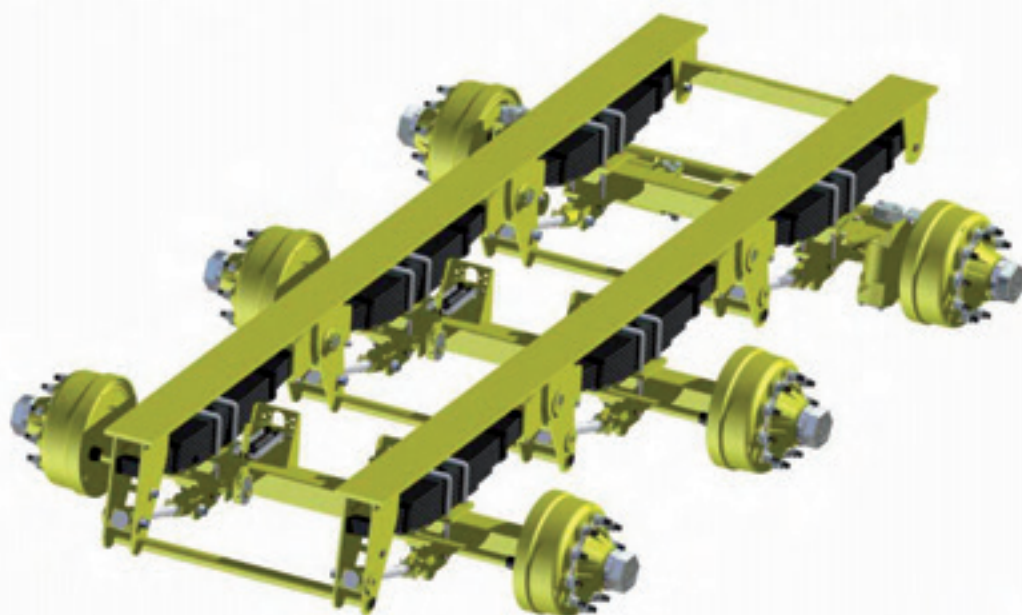



TRIDEMS A BIELLES AVEC RESSORTS MULTILAMES

TRIDEMS WITH TIE ROD AND MULTI-LEAF SPRINGS

TRIDEMS CON BIELAS Y BALLESTAS MULTIHOJAS



POSITION BASSE

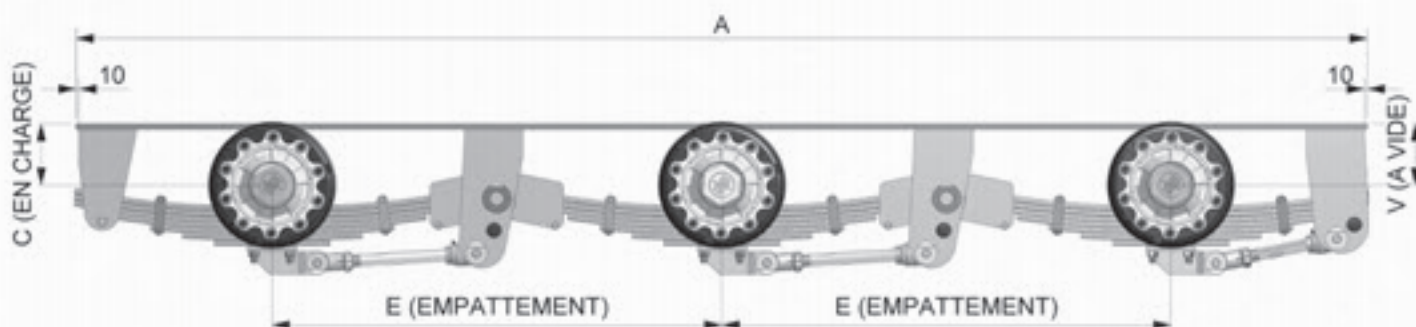

| CHARGE/LOAD/CARGA | EMPATTEMENT E (mm) | TYPE RESSORT TYPE SPRING BALLESTA NB - L x EP. (mm) | A mm | □110 | | □130 | | □150 | |
|-------------------|-----------------------|--|-------------|------|-----|------|-----|------|-----|
| | | | | V | C | V | C | V | C |
| KGS | | | | mm | | | | | |
| 30 000 | 1550 / 1700 | 7/3 - 100 x 20 | 4450 / 4750 | 208 | 168 | | | | |
| | 1670 / 1820 | 8/4 - 100 x 20 | 4810 / 5110 | 208 | 168 | | | | |
| 32 000 | 1670 / 1820 | 8/4 - 100 x 20 | 4810 / 5110 | | | 198 | 158 | 188 | 148 |

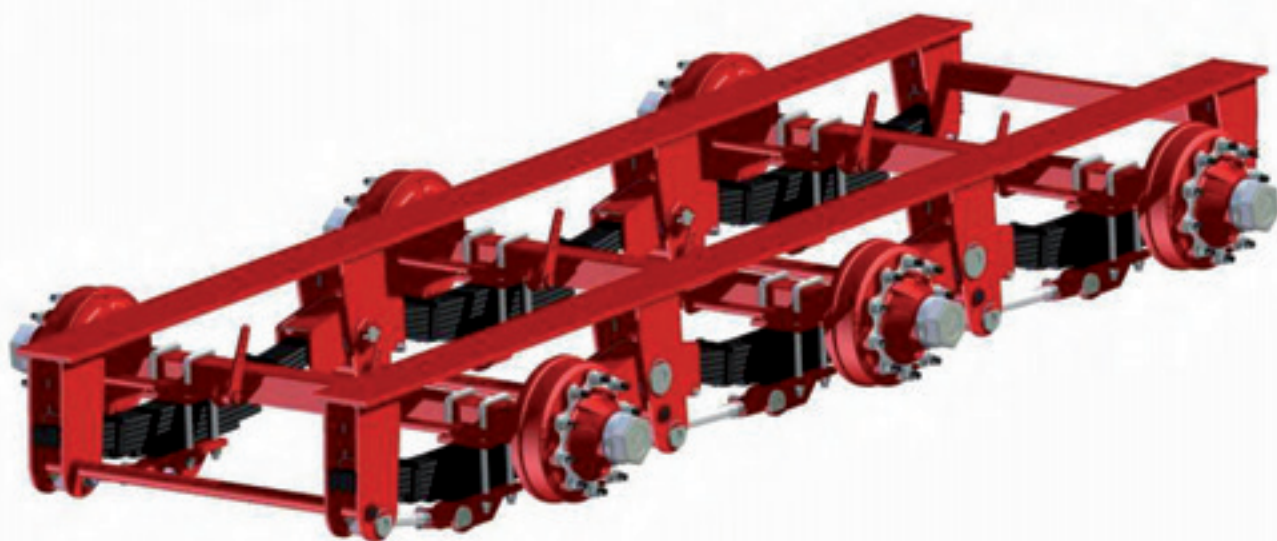



TRIDEMS A BIELLES AVEC RESSORTS PARABOLIQUES

TRIDEMS WITH TIE ROD AND PARABOLIC SPRINGS

TRIDEMS CON BIELAS Y BALLESTAS PARABOLICAS



POSITION HAUTE

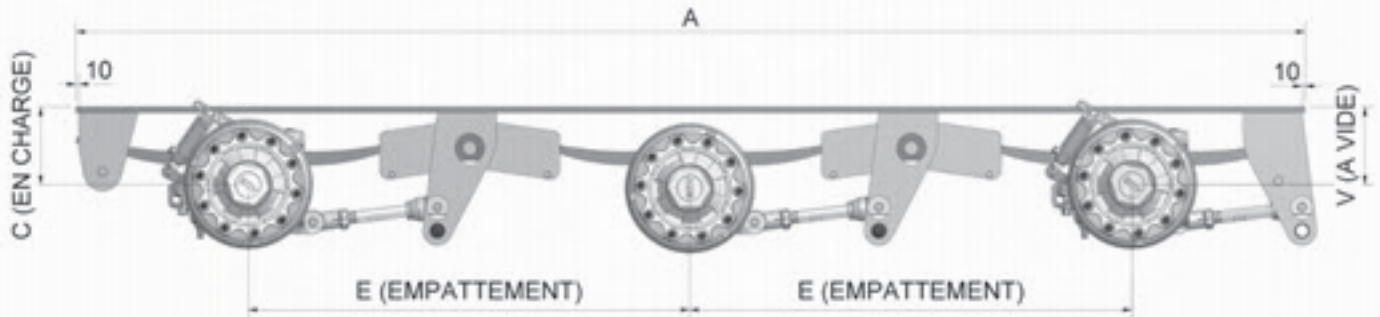

| CHARGE/LOAD/CARGA | EMPATTEMENT E (mm) | TYPE RESSORT TYPE SPRING BALLESTA NB - L x EP. (mm) | A mm | □100 | | □110 | | □130 | |
|-------------------|-----------------------|--|-------------|------|-----|------|-----|------|-----|
| | | | | V | C | V | C | V | C |
| KGS | | | | mm | | | | | |
| 24 000 | 1350 / 1500 | 1 - 100 x 45 | 3910 / 4170 | 268 | 238 | | | | |
| | 1350 / 1500 | 3 - 100 x 24 | 3850 / 4150 | 326 | 286 | | | | |
| 30 000 | 1350 / 1500 | 1 - 100 x 45 | 3910 / 4170 | | | 273 | 243 | 283 | 253 |
| | 1350 / 1500 | 3 - 100 x 24 | 3850 / 4150 | | | 331 | 291 | 341 | 301 |
| | 1450 / 1600 | 3 - 100 x 27 | 4150 / 4450 | | | 345 | 305 | 355 | 315 |

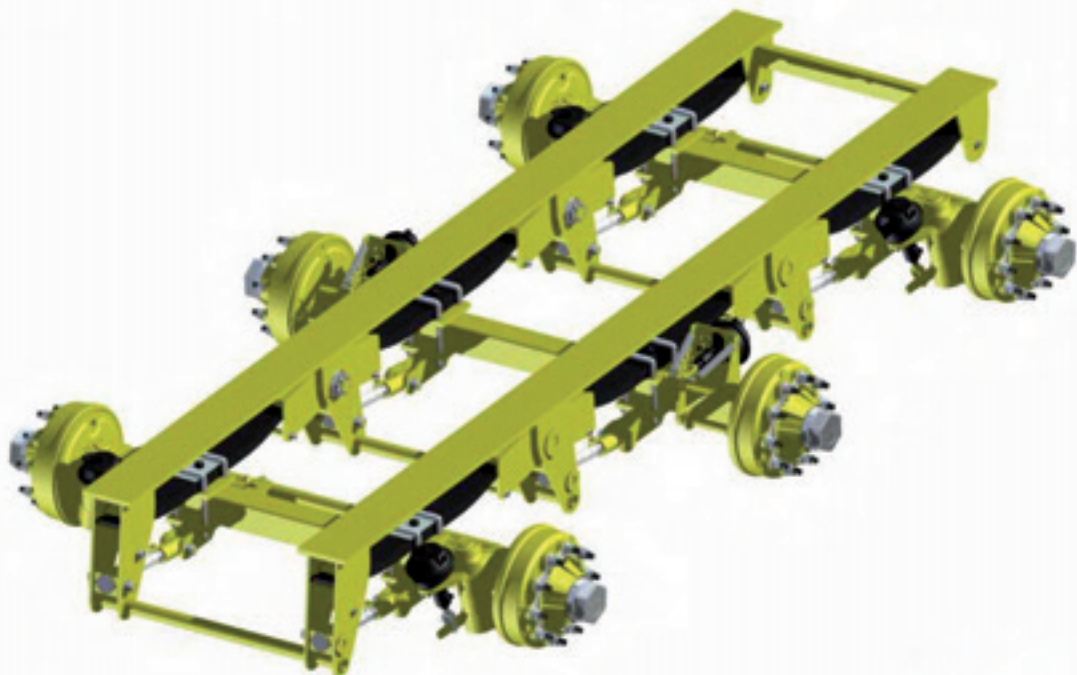

ESSIEUX BOURGOGNE

PAGE 28





**BALANCIERS PLIES
PENDULAR AXLES
BALANCINES PLEGADOS**

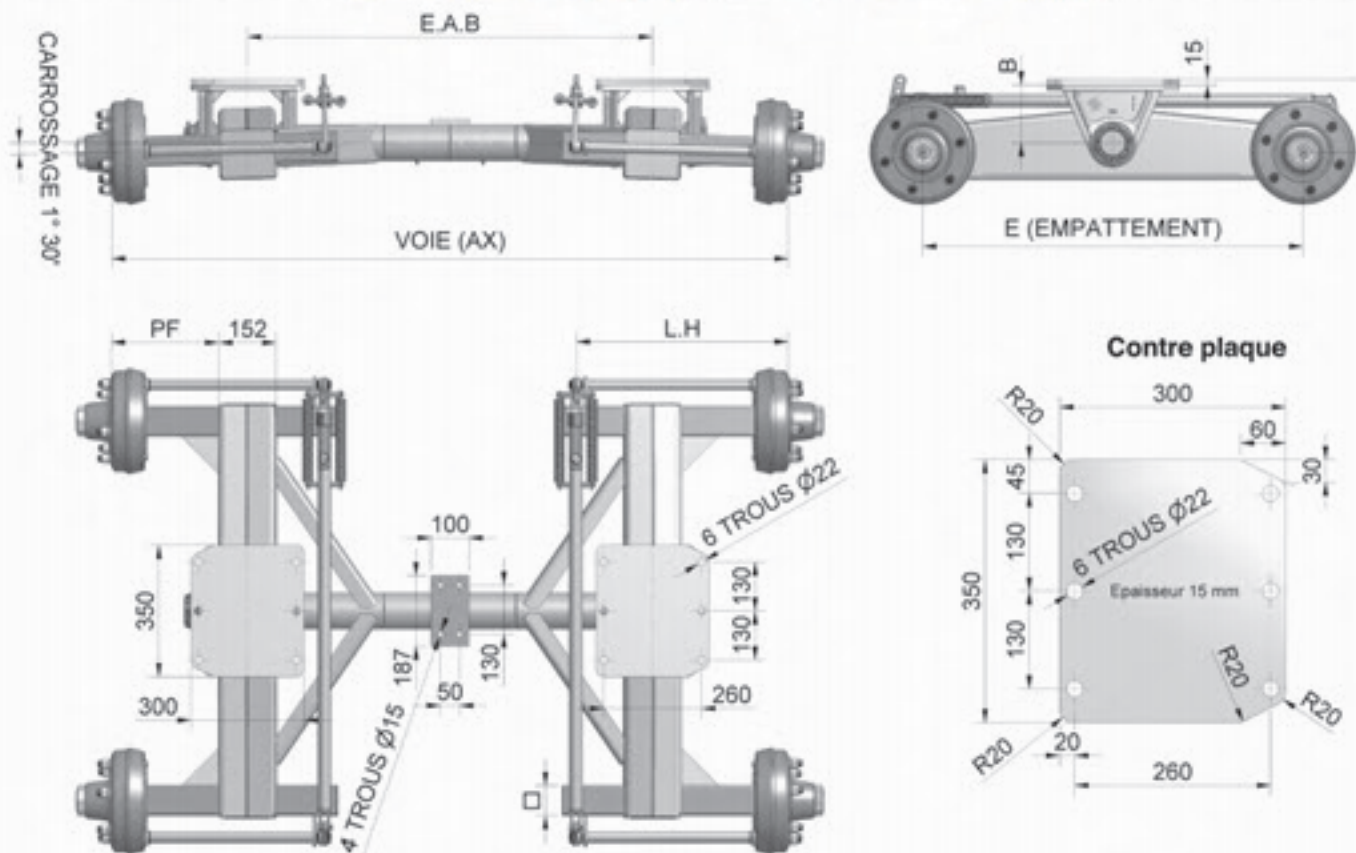

| CHARGE/LOAD /CARGA | CARRE SQUARE CUADADRO | NB AXES | EMPATTEMENT | B | PORTE A FAUX STANDARD | VOIE (AX) | E.A.B |
|-----------------------|-----------------------------|-----------|-------------|-----|--------------------------|------------|-------|
| | | NB STUD | | | | TRACK (AX) | |
| KGS | □ | NB COLONA | E (mm) | mm | mm | PISTA (AX) | |
| 9 000 | □80 | 6 | 1010 / 1180 | 155 | 260 | 1900 | 1228 |
| 11 000 | □80 | 8 | 1180 | 155 | 310 | 2100 | 1328 |

ENTRAXE BRAS E.A.B : A DETERMINER EN FONCTION DE LA VOIE(AX) ET DU PORTE A FAUX
 $E.A.B = VOIE(AX) - (152 + 2 \times PORTE A FAUX)$

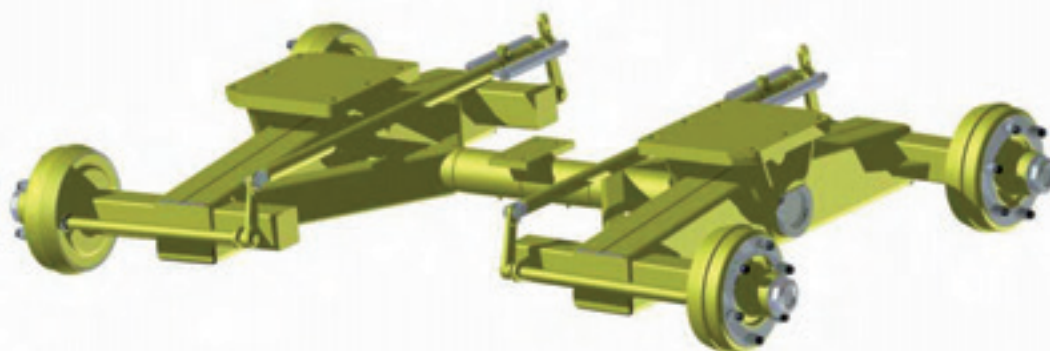



**BALANCIERS OXYCOUPES
PENDULAR AXLES OXYCUT
BALANCINES OXYCORTE**

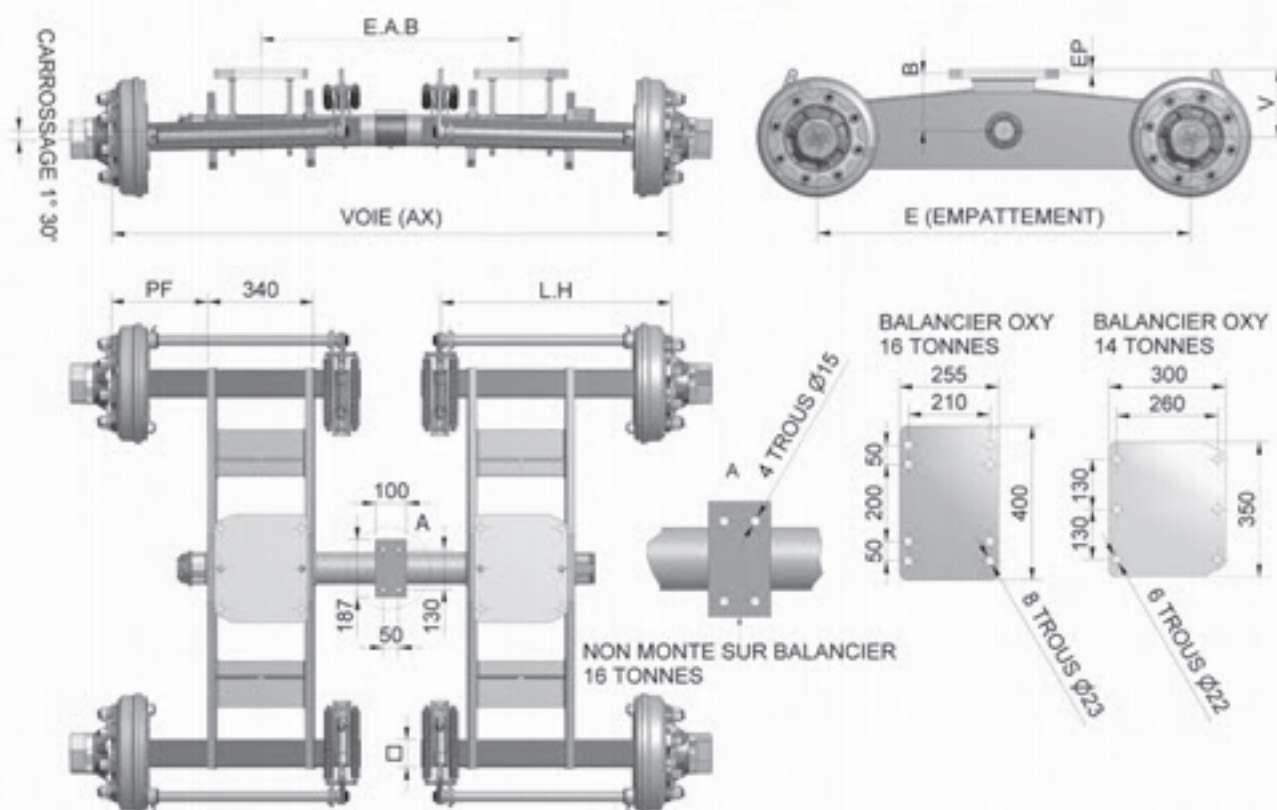

| CHARGE/LOAD /CARGA | CARRE SQUARE CUADADRO | NB AXES NB STUD NB COLONA | EMPATTEMENT E (mm) | PORTE A FAUX STANDARD mm | VOIE (AX) | B | E.A.B | V | EP |
|-----------------------|-----------------------------|---------------------------------|-----------------------|--------------------------------|------------|-----|-------|-----|----|
| | | | | | TRACK (AX) | | | | |
| 12 000 | □80 | 8 | 1200 | 310 | 1900 | 185 | 940 | 210 | 15 |
| 14 000 | □90 | 8 | 1200 | 310 | 2000 | 185 | 1040 | 210 | 15 |
| 16 000 | □100 | 10 | 1400 | 400 | 2100 | 190 | 960 | 155 | 12 |

ENTRAXE BRAS E.A.B : A DETERMINER EN FONCTION DE LA VOIE(AX) ET DU PORTE A FAUX
 $E.A.B = VOIE(AX) - (340 + 2 \times PORTE A FAUX)$

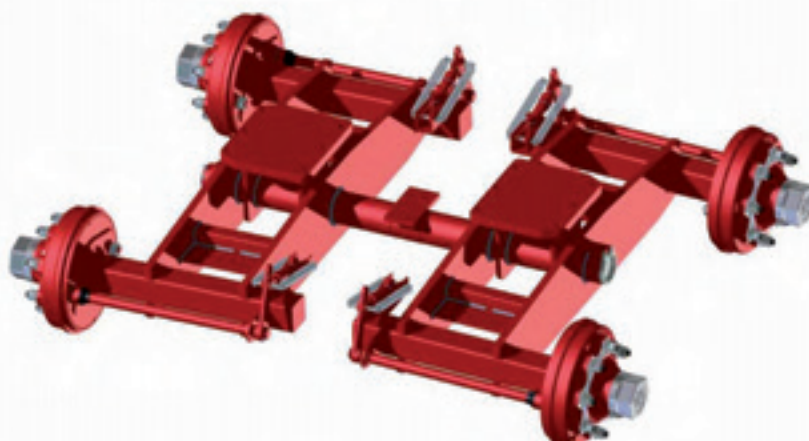



BALANCIERS OXYCOUPES TP
PENDULAR AXLES OXYCUT PUBLIC WORKS
BALANCINES OXYCORTE OBRAS PUBLICAS

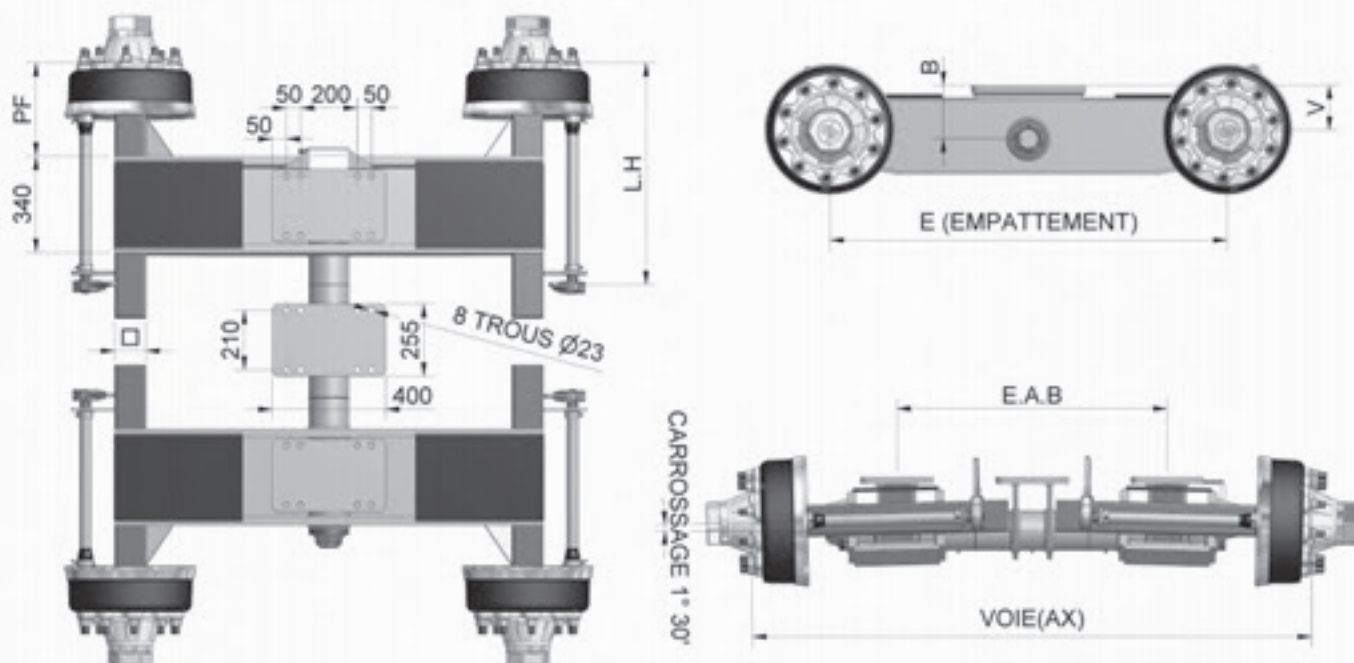

| CHARGE/LOAD /CARGA | CARRE SQUARE CUADADRO | NB AXES | EMPATTEMENT | PORTE A FAUX STANDARD | VOIE (AX) | B | E.A.B | V |
|-----------------------|-----------------------------|-----------|-------------|--------------------------|------------|-----|-------|-----|
| | | NB STUD | | | TRACK (AX) | | | |
| KGS | □ | NB ATAQUE | E (mm) | mm | PISTA (AX) | mm | | |
| 22 000 | □110 | 10 | 1400 | 325 | 2000 | 190 | 1010 | 158 |
| 22 000 | □130 | 10 | 1400 | 325 | 2000 | 190 | 1010 | 158 |

ENTRAXE BRAS E.A.B : A DETERMINER EN FONCTION DE LA VOIE(AX) ET DU PORTE A FAUX
 $E.A.B = VOIE(AX) - (340 + 2 \times PORTE A FAUX)$

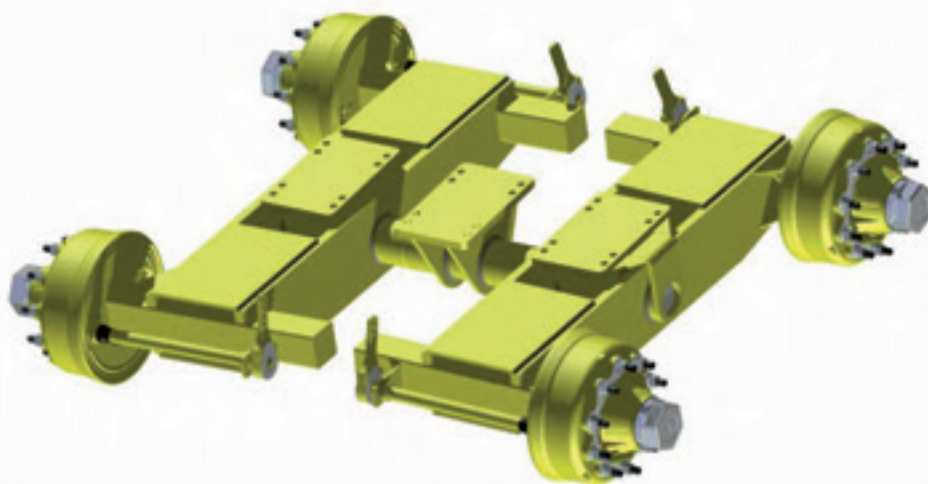



**RESSORTS DE FLECHE
DRAWBAR SPRINGS
BALLESTAS DE LANZA**

**TYPE 2500 (CHARGE MAXI : 1800 Kg)
7 LAMES 120x14**

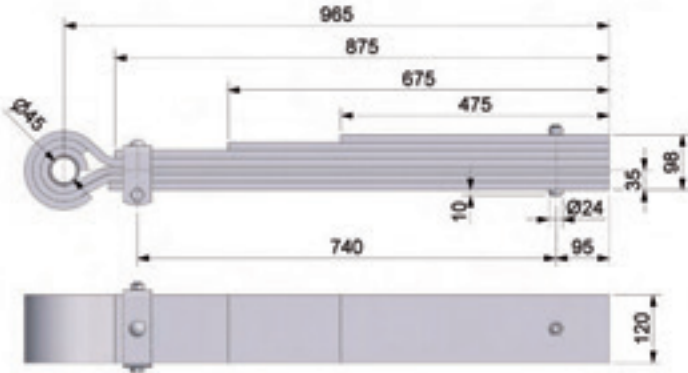

**TYPE 3500 (CHARGE MAXI : 3400 Kg)
13 LAMES 120x14**

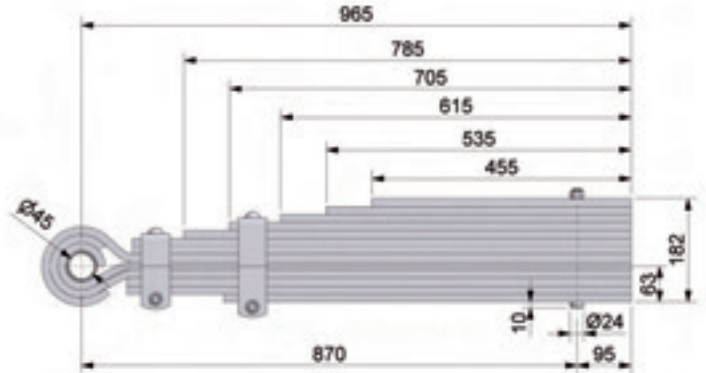

**TYPE 2800 (CHARGE MAXI : 2500 Kg)
9 LAMES 120x14**

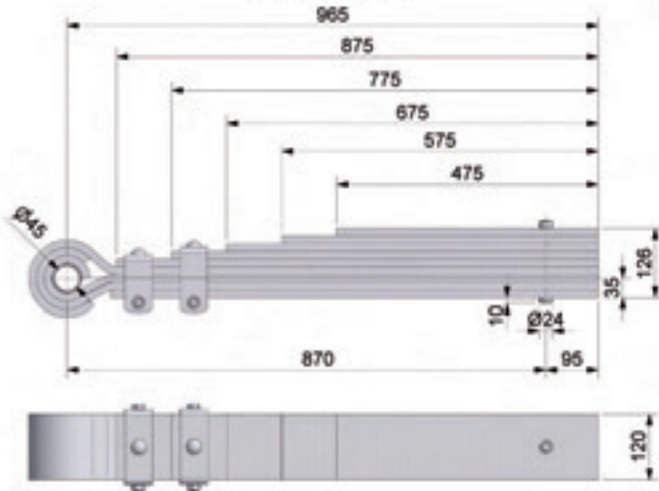

**TYPE 4000 (CHARGE MAXI : 3900 Kg)
15 LAMES 120x14**

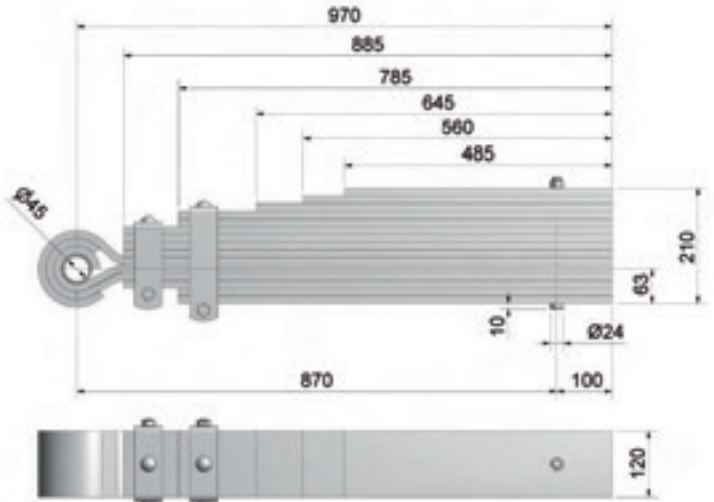

**TYPE 3000 (CHARGE MAXI : 2900 Kg)
11 LAMES 120x14**

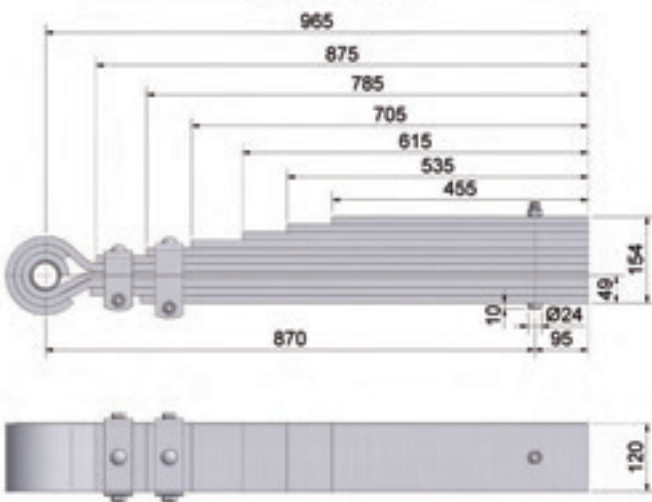

S/ENS AXE RESSORT FLECHE

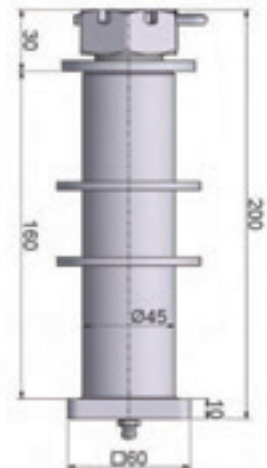



ROULEMENTS A ROULEAUX CONIQUES
CONICAL BEARINGS
RODAMIENTOS CONICOS



| CODE CODE CODIGO | DIMENSIONS DIMENSIONS | | | CHARGE DE BASE EN daN | | CODE CODE CODIGO | DIMENSIONS DIMENSIONS | | | CHARGE DE BASE EN daN | |
|------------------------|--------------------------|-----|---------|--------------------------|-------------|------------------------|--------------------------|-----|---------|--------------------------|-------------|
| | d | D | T MOYEN | DYNAMIQUE C | STATIQUE Co | | d | D | T MOYEN | DYNAMIQUE C | STATIQUE Co |
| 32204 V | 20 | 47 | 19.25 | 2 680 | 2 120 | 30203 V | 17 | 40 | 13.25 | 1 910 | 1 430 |
| 32205 V | 25 | 52 | 19.25 | 2 950 | 2 410 | 30204 V | 20 | 47 | 15.25 | 2 190 | 1 640 |
| 32206 V | 30 | 62 | 21.25 | 3 900 | 3 250 | 30205 V | 25 | 52 | 16.25 | 2 250 | 1 710 |
| 32207 V | 35 | 72 | 24.25 | 5 400 | 4 700 | 30206 V | 30 | 62 | 17.25 | 3 100 | 2 470 |
| 32208 V | 40 | 80 | 24.75 | 5 700 | 4 800 | 30207 V | 35 | 72 | 18.25 | 3 850 | 3 000 |
| 32209 V | 45 | 85 | 24.75 | 6 200 | 5 400 | 30208 V | 40 | 80 | 19.75 | 4 400 | 3 450 |
| 32210 V | 50 | 90 | 24.75 | 6 400 | 5 500 | 30209 V | 45 | 85 | 20.75 | 5 100 | 4 200 |
| 32211 V | 55 | 100 | 26.75 | 7 900 | 6 900 | 30210 V | 50 | 90 | 21.75 | 5 900 | 5 000 |
| 32212 V | 60 | 110 | 29.75 | 9 900 | 8 900 | 30211 V | 55 | 100 | 22.75 | 7 300 | 6 200 |
| 32213 V | 65 | 120 | 32.75 | 11 500 | 10 400 | 30212 V | 60 | 110 | 23.75 | 7 700 | 6 400 |
| 32214 V | 70 | 125 | 33.25 | 11 900 | 10 900 | 30213 V | 65 | 120 | 24.75 | 9 100 | 7 600 |
| 32215 V | 75 | 130 | 33.25 | 12 200 | 11 200 | 30214 V | 70 | 125 | 26.25 | 9 200 | 7 800 |
| 32216 V | 80 | 140 | 35.25 | 13 700 | 12 500 | 30215 V | 75 | 130 | 27.25 | 9 700 | 8 300 |
| 32217 V | 85 | 150 | 38.50 | 15 800 | 14 600 | 30216 V | 80 | 140 | 28.25 | 11 000 | 9 400 |
| 32218 V | 90 | 160 | 42.50 | 19 400 | 18 600 | 30217 V | 85 | 130 | 30.50 | 13 000 | 11 300 |
| 32219 V | 95 | 170 | 45.50 | 21 500 | 20 800 | 30218 V | 90 | 160 | 32.50 | 15 000 | 13 400 |
| 32220 V | 100 | 180 | 49.00 | 24 100 | 23 500 | 30219 V | 95 | 170 | 24.50 | 16 700 | 15 000 |
| 32221 V | 105 | 190 | 53.00 | 28 000 | 28 000 | 30220 V | 100 | 180 | 37.00 | 19 200 | 17 600 |
| 33009 | 45 | 75 | 24.00 | 5 400 | 5 300 | 30221 V | 105 | 190 | 39.00 | 21 600 | 20 000 |
| 33010 | 50 | 80 | 24.00 | 5 700 | 5 800 | 32010 | 50 | 80 | 20.00 | 4 600 | 4 200 |
| 33011 | 55 | 90 | 27.00 | 7 500 | 7 800 | 32011 | 55 | 90 | 23.00 | 5 900 | 5 800 |
| 33012 | 60 | 95 | 27.00 | 7 700 | 8 100 | 32012 | 60 | 95 | 23.00 | 6 000 | 6 000 |
| 33013 | 65 | 100 | 27.00 | 8 300 | 8 800 | 32013 | 65 | 100 | 23.00 | 6 300 | 6 500 |
| 33014 | 70 | 110 | 31.00 | 9 500 | 10 100 | 32014 | 70 | 110 | 25.00 | 7 900 | 7 500 |
| 33015 | 75 | 115 | 31.00 | 10 000 | 11 000 | 32015 | 75 | 115 | 25.00 | 8 300 | 8 200 |
| 33016 | 80 | 125 | 36.00 | 12 600 | 13 800 | 32016 | 80 | 125 | 29.00 | 10 300 | 10 300 |
| 33017 | 85 | 130 | 36.00 | 13 700 | 15 600 | 32017 | 85 | 130 | 29.00 | 10 900 | 11 200 |
| 33018 | 90 | 140 | 39.00 | 14 800 | 15 800 | 32018 | 90 | 140 | 29.00 | 12 400 | 12 900 |
| 33019 | 95 | 145 | 39.00 | 15 800 | 17 300 | 32019 | 95 | 145 | 32.00 | 12 600 | 13 400 |
| 33020 | 100 | 150 | 39.00 | 16 700 | 18 800 | 32020 | 100 | 150 | 32.00 | 12 900 | 13 900 |
| 33021 | 105 | 160 | 43.00 | 17 600 | 19 300 | 32021 | 105 | 160 | 35.00 | 16 100 | 17 200 |



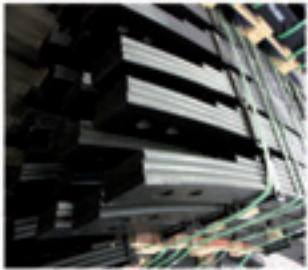

CONTRE – PLAQUES BOGGIE
BOGGIE MOUNTING PLATES
SOBRE PLACAS DE BOGGIE

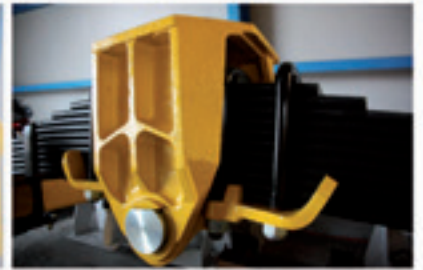

Contre plaque Standard
Boggie 5 à 7 Lames

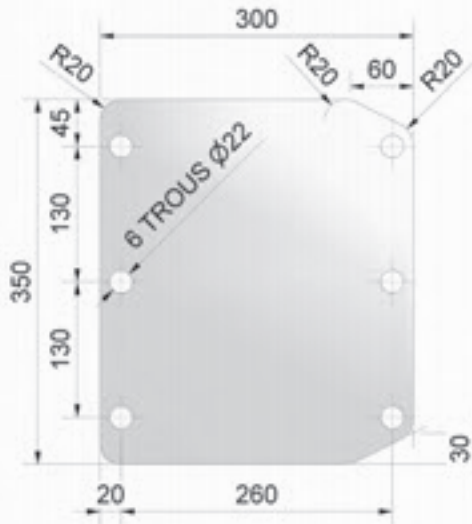

Contre plaque Standard
Boggie 8 à 11 Lames

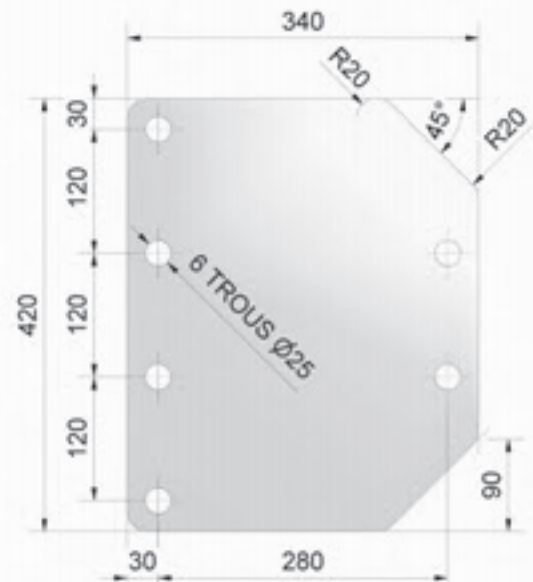

Contre plaque Option
Boggie 5 à 11 Lames

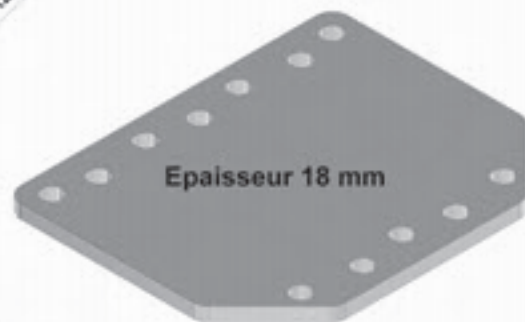
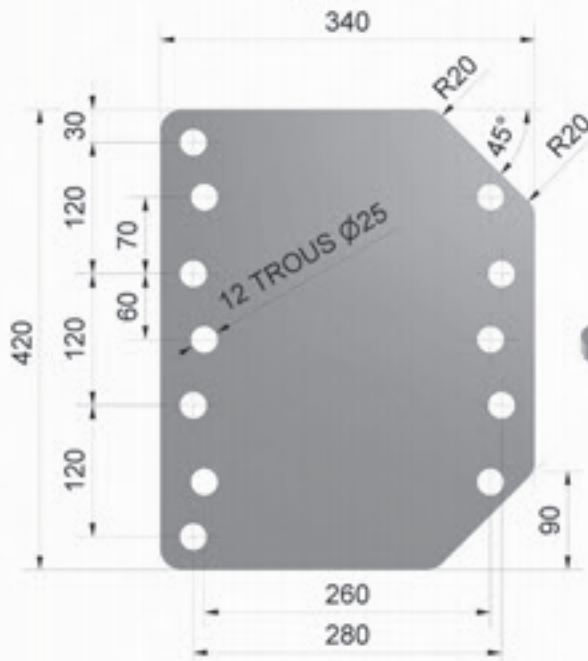



**DOUBLE BRIDAGE
MOUNTING FRAME WITH 4 U-BOLTS
AMARRADO CON 4 ABARCONES**



DOUBLE BRIDAGE CHAISE

BOGIE MOUNTING FRAME WITH 4 U-BOLTS

SOPORTE DE BOGIE AMARRADO CON 4 ABARCONES

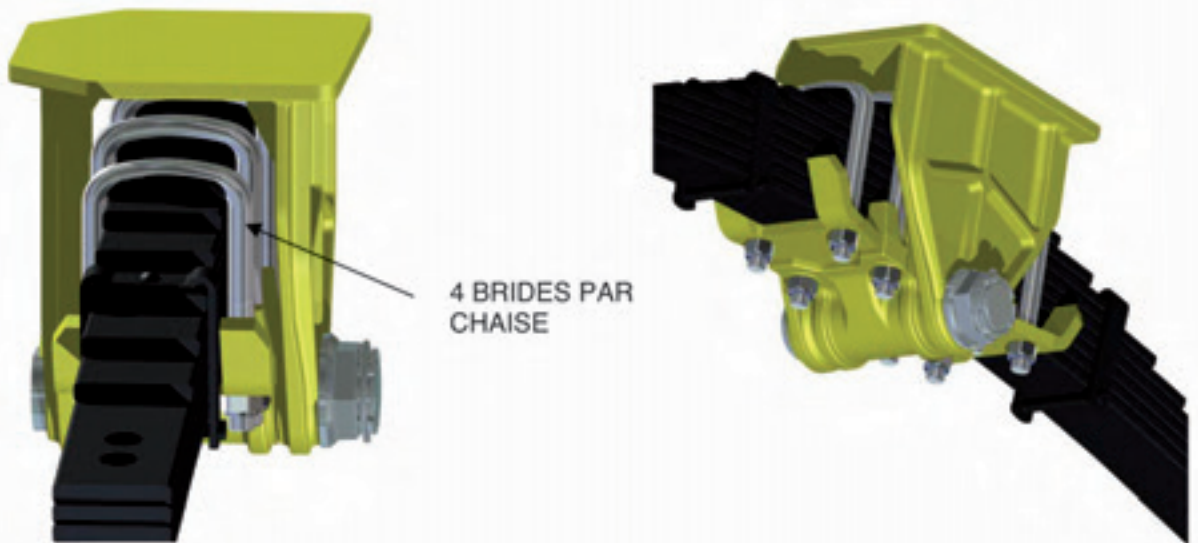

**4 BRIDES PAR
CHAISE**

DOUBLE BRIDAGE BOITIER ESSIEU

BOGIE SPRING FASTENING KIT WITH 4 U-BOLTS

KIT DE AMARRE AL EJE CON 4 ABARCONES

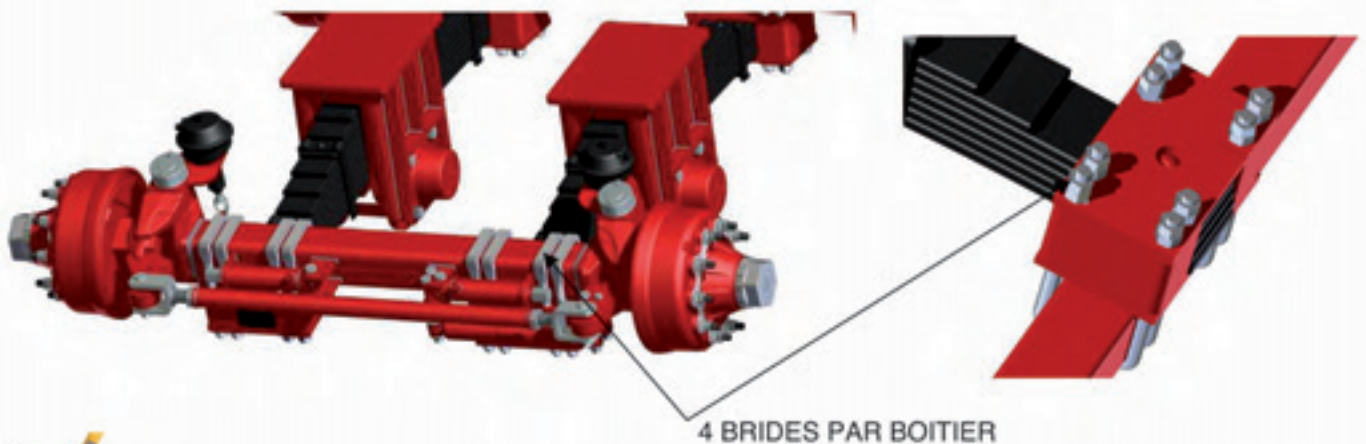

4 BRIDES PAR BOITIER



ESSIEUX BOURGOGNE

PAGE 35

AMB



FREINAGE HYDRAULIQUE
BRAKE CYLINDER HYDRAULIC
FRENADO HIDRAULICO



| TYPE TYPE TIPO | L mm | D1 mm | D2 mm | D3 mm |
|----------------------|---------|----------|----------|----------|
| 20 | 243 | 20 | 30 | 16 |
| 25 | 243 | 25 | 35 | 16 |
| 30 | 243 | 30 | 42 | 16 |
| 35 | 243 | 35 | 50 | 16 |



FREINAGE MIXTE OU AIR
DUAL SUPPLY OR AIR ACTUATORS
CYLINDRO MIXTO OR AIRE



| TYPE/ TYPE/TIPO | A mm | D1 mm | D2 mm | D3 mm | L |
|--------------------|---------|----------|----------|----------|-------|
| 20 - 30 Mixte | 120.7 | 151 | 176 | 75-78 | 114 |
| 24 - 35 Mixte | 120.7 | 161 | 185 | 75-78 | 117 |
| 20 - Air | 120.7 | 151 | 177 | 75 | 112 |
| 24 - Air | 120.7 | 160 | 186 | 75 | 118.5 |
| 30 - Air | 120.7 | 182.5 | 210 | 75 | 120.5 |
| 36 - Air | 120.7 | 200 | 233 | 75 | 115 |





DIMENSIONS BIELLETTES ET LEVIERS REGLEURS

DIMENSIONS OF STANDARD AND ADJUSTABLE BRAKE LEVER

DIMENSIONES DE LAS PALANCAS DE FRENO NORMALES Y REGULABLE

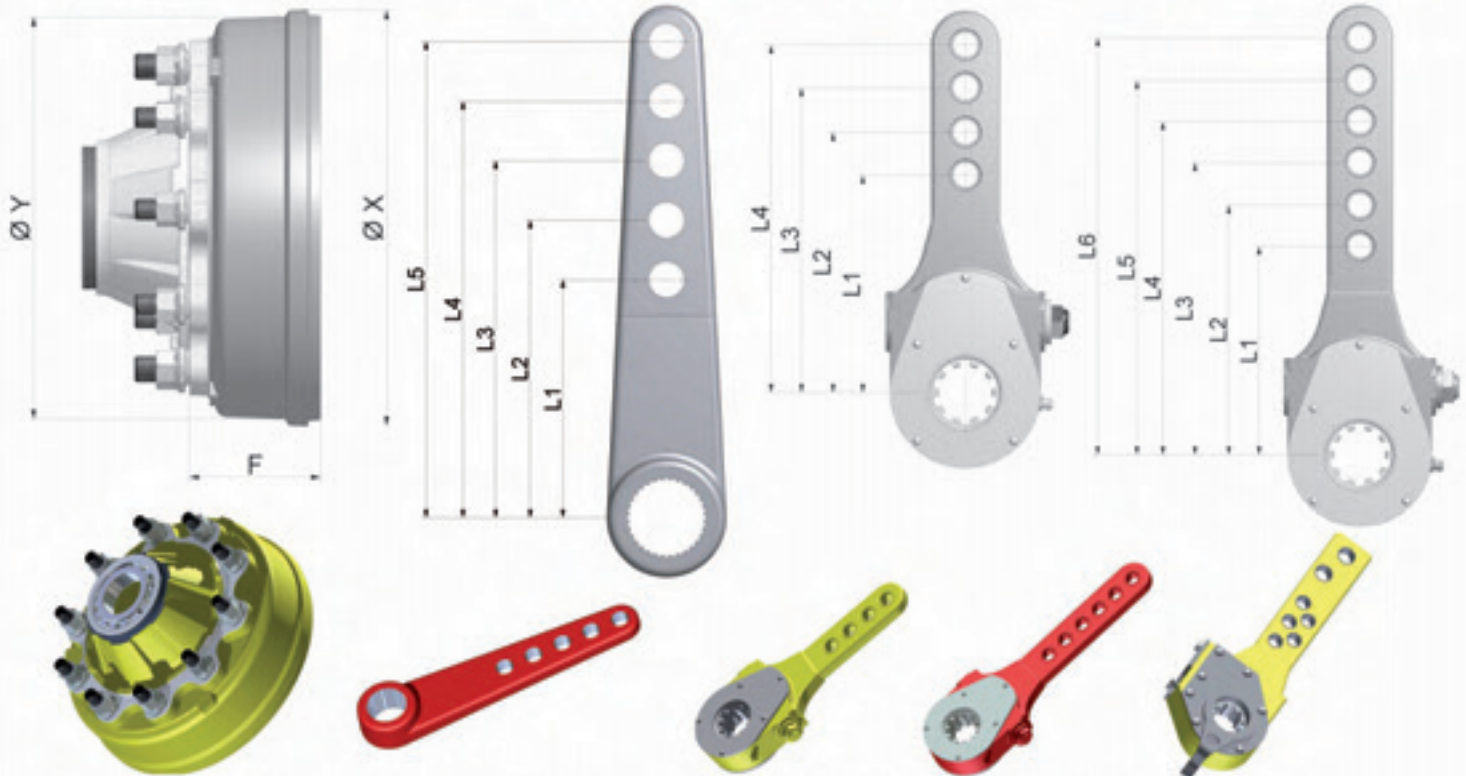

LEVIER OU BIELLETTTE : B

LEVIER REGLEUR : LR

LEVIER AUTOREGLEUR : LA

| FREIN BRAKE FRENO | Ø X mm | Ø Y mm | F mm | L1 / L2 / L3 / L4 / L5 / L6 / L7 mm | Nombre Dents |
|-------------------------|-------------|-----------|---------|--|-----------------|
| 250x60 | 280 | 270 | 86 | B : 100 / 125 / 150 / 180 | 32 DENTS |
| 300x60 | 328 MFG/335 | 320 | 92 | B : 100 / 125 / 150 / 180 | 32 DENTS |
| 350x60 | 378 MF/390 | 375 | 112 | B : 100 / 125 / 150 / 175 / 200 | 32 DENTS |
| | | | | LR : 125 / 150 / 175 / 200 / 225 / 255 | 32 DENTS |
| 350x90 | 390 | 383 | 170 | B : 100 / 125 / 150 / 175 / 200 | 32 DENTS |
| | | | | LR : 125 / 150 / 175 / 200 / 225 / 255 | 32 DENTS |
| 400x80 | 438 | 423 | 138 | B : 100 / 125 / 150 / 175 / 200 | 32 DENTS |
| | | | | LR : 125 / 150 / 175 / 200 / 225 / 255 | 32 DENTS |
| 406x120 | 459 | 436 | 182 | LR : 127 / 152 / 178 / 203 | 10 DENTS |
| | | | | LR : 127 / 152 / 178 / 203 / 228 / 254 | 10 DENTS |
| | | | | LA : 120 / 135 / 150 / 165 / 180 / 225 / 260 | 10 DENTS |
| 406x140 | 460 | 442 | 197 | LR : 127 / 152 / 178 / 203 | 10 DENTS |
| | | | | LR : 127 / 152 / 178 / 203 / 228 / 254 | 10 DENTS |
| | | | | LA : 120 / 135 / 150 / 165 / 180 / 225 / 260 | 10 DENTS |
| 420x180 | 478 | 454 | 247 | LR : 127 / 152 / 178 / 203 | 10 DENTS |
| 420x200 | | | | LR : 127 / 152 / 178 / 203 / 228 / 254 | 10 DENTS |
| | | | | LA : 120 / 135 / 150 / 165 / 180 / 225 / 260 | 10 DENTS |



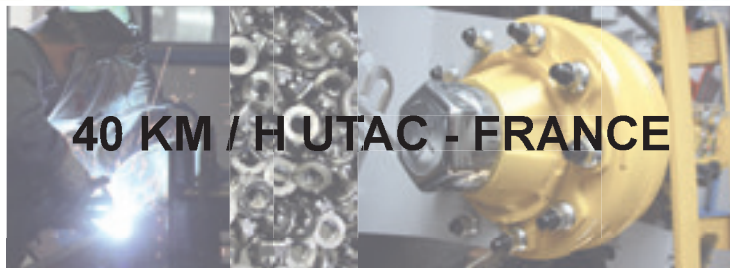

40 KM / H UTAC - FRANCE

 Afin de répondre à la nouvelle Réglementation Française permettant aux véhicules agricoles de pouvoir rouler à 40 Km/h, Essieux Bourgogne présente les produits agréés par l'UTAC et disponibles dès à présent :

 In order to comply with the requirements of the new French regulation allowing agricultural vehicles to operate at 40km/h, Essieux Bourgogne introduces its products that have been approved by the UTAC and that are now available:

 Con el fin de cumplir con la nueva normativa Francesa que permite a los vehículos agrícolas circular a 40 km/h, Essieux Bourgogne les presenta sus productos que fueron aprobados por la UTAC y que son disponibles ahora:

| CARACTERISTIQUES DES ENVELOPPES DEFINIES PAR AXEMA (SNCVA) – 5 JUIN 2008 | POIDS TOTAL EN CHARGE / PTAC (EN TONNE) TOTAL WEIGHT UNDER LOAD / GVWR (TONS) PESO TOTAL BAJO CARGA (EN TONELEDAS) | | | |
|---|--|--|--|--|
| | 20,5 T | 24 T | 29T | 32 T |
| <ul style="list-style-type: none"> • MASSE MAXIMALE SUR LES ESSIEUX DU VEHICULE EN CHARGE (en tonne) • MAXIMUM WEIGHT ON THE AXLES UNDER LOAD (tons) • PESO MÁXIMO SOBRE LOS EJES DEL VEHÍCULO BAJO CARGA (en Toneledas) | 17,5 T | 21 T | 26T | 29 T |
| <ul style="list-style-type: none"> • TAILLE DE PNEU MAXIMALE • SIZE OF THE TIRES MAXIMUM • TAMAÑO DE LOS NEUMÁTICOS MÁXIMO | 560/60 R22,5 | 710/50 R26,5 | 800/45 R30.5 | 710/50 R26,5 |
| <ul style="list-style-type: none"> • DIMENSION DES FREINS • BRAKE SIZE • DIMENSIÓN DE LOS FRENOS | 406 x 120 | 406 x 140 | 420x200 | 406 x 140 |
| <ul style="list-style-type: none"> • TYPE D'ENSEMBLE SUSPENDU • TYPE OF SUSPENSIONS • TIPO DE SUSPENSIÓN | TANDEM | TANDEM | TANDEM | TRIDEM |
| <ul style="list-style-type: none"> • CIRCUIT DE FREINAGE • BRAKING CIRCUIT • CIRCUITO DE FRENADO | Pneumatique Pneumatic Neumatico | Pneumatique Pneumatic Neumatico | Pneumatique Pneumatic Neumatico | Pneumatique Pneumatic Neumatico |
| <ul style="list-style-type: none"> • CAPACITE TOTALE DU RESERVOIR A AIR (en litre) • TOTAL CAPACITY OF THE AIR TANKS (liters) • CAPACIDAD TOTAL DE LOS TANQUES DE AIRE (litros) | 60 | 90 | 90 | 120 |
| <ul style="list-style-type: none"> • COTE D'ACCROCHE DU FREINAGE (en mm) • POSITION OF THE BRAKE CYLINDER ON THE BRAKE LEVER (in mm) • POSICIÓN DEL CILINDRO DE FRENO SOBRE LA PALANCA DE FRENO (en mm) | 150 | 150 / 180 | 180 / 180 | 135 / 150 / 165 |
| <ul style="list-style-type: none"> • ACTIONNEUR DES FREINS • PNEUMATIC BRAKE ACTUATOR • ACTUADOR DE FRENO NEUMÁTICO | VASES Ø24" Essieu N°1 1st Axle Eje N°1 VASES Ø30" Essieu N°2 2nd Axle Eje N°2 | VASES Ø30" Par Essieu For each Axle Para cada Eje | VASES Ø30" Par Essieu For each Axle Para cada Eje | VASES Ø30" Par Essieu For each Axle Para cada Eje |



Nota : Pour toute autre demande 40KM/H, nous consulter.





NOTICE LIVRAISON / ENTRETIEN
DELIVERY INSTRUCTION / MAINTENANCE MANUAL
INSTRUCCIONES DE ENTREGA / MANTENIMIENTO



NOTICE DE LIVRAISON DES VEHICULES

Compte-tenu du fait qu'au montage de nos essieux les roulements sont réglés serrés pour qu'après 4 ou 5 voyages en charge les moyeux retrouvent une rotation libre et sans jeu, il est absolument interdit de livrer les véhicules chez les concessionnaires ou chez les utilisateurs derrière un camion dépassant la vitesse de 25 km/h ou 40 km/h. Au-delà de cette vitesse, vous vous exposez à des détériorations de roulements.

NOTICE D'ENTRETIEN

Tous nos essieux sont graissés et réglés lors du montage en nos usines. Chaque essieu est prévu pour la charge indiquée sur la documentation générale et pour une vitesse d'utilisation de 25 km/h ou 40 km/h suivant la législation.

Une fois par an, il y a lieu de contrôler le jeu des roulements et le graissage, ainsi que l'usure des garnitures, d'effectuer en même temps un dépoussiérage de l'ensemble frein et un réglage de la course du levier de frein pour qu'elle soit au minimum.

A chaque démontage, changer la goupille sur écrou de fusée. En cas d'utilisation intensive, ces opérations sont à effectuer tous les 3 mois.

Lors de la mise en service, vérifier le serrage des écrous de roue :
 • Après 10 km
 • Après 50 km
 • Ensuite tous les mois
 Même opération lors du démontage des roues.

Couple de serrage écrous de roue :

- Ø 16 à 12 à 14 m daN
- Ø 18 à 26 à 29 m daN
- Ø 22 à 45 à 50 m daN

Pas de peinture sur les faces d'appui de roue des moyeux.

Pour les boggies, graisser les articulations centrales tous les mois et vérifier le bon serrage des écrous d'étriers.
Pour les essieux sulveurs, graisser les pivots d'articulation tous les mois.

VEHICLE DELIVERY INSTRUCTIONS

Considering that during the assembly of our axles the bearings are adjusted tightened so that after 4 or 5 travels under load the hubs are free to rotate easily without end play, it is strictly forbidden to deliver the vehicles to equipment dealers or end-users behind a truck exceeding 25 km/h or 40 km/h. Beyond this speed limit, the bearings could be damaged.

MAINTENANCE MANUAL

All our axles were greased and adjusted while assembling in our factories. Each axle is capable of withstanding the carrying capacity specified in our catalogue with an operating speed of 25 km/h or 40 km/h according road regulation.

Once a year:

- the end play and the greasing of the bearings must be checked as well as the wear of the brake linings,
- a dust removal of the complete brake unit must be done as well as an adjustment of the brake lever stroke (in order to ensure a minimum stroke length).

After each disassembly, change the split pin from the spindle (castellated) nut.

In case of intensive use, those operations must be carried out every 3 months.

When putting into service, check the tightening of the wheel nuts:

- after 10 km
- after 50 km
- then every month

Repeat the same operation when disassembling the wheels.

Wheel nuts torque:

- Ø 16 a 12 to 14 m da N
- Ø 18 a 26 to 29 m da N
- Ø 22 a 45 to 50 m da N

No paint on the hub surfaces.

Bogies: Grease the central articulations of the bogie mounting frames every month and check the tightening of the leaf spring U-bolt.

Steering axles: Grease the pivot shafts of the steering axles every month.

INSTRUCCIONES DE ENTREGA DE LOS VEHICULOS

Teniendo en cuenta que al montar nuestros ejes ajustamos los rodamientos apretados para que después de 4 o 5 viajes bajo carga los bujes vuelvan girar libremente y sin juego, queda absolutamente prohibido entregar los vehículos a los concesionarios o a los usuarios detrás de un camión circulando a más de 25 km/h o 40 km/h. Más allá de esta velocidad, se podrían estropear los rodamientos.

MANUAL DE MANTENIMIENTO

Todos nuestros ejes son engrasados y ajustados durante el montaje en nuestras fábricas. Cada eje está concebido para aguantar la carga señalada en la documentación general y para una velocidad de uso de 25 km/h o 40 km/h según reglamentación de camino.

Una vez al año, es preciso comprobar el juego y el engraso de los rodamientos así como el desgaste de los forros de freno. Es menester desempolvacar el conjunto de freno y ajustar el recorrido de la leva de freno para que sea lo más corto posible. Después de cada desmontaje, cambie el pasador de aletas de la tuerca almenada del eje.

En caso de uso intensivo, es preciso repetir estas operaciones cada 3 meses.

Durante la puesta en servicio del vehículo, compruebe el ajuste de lastuercas

- después de 10 km
- después de 50 km
- y luego, cada mes

Repita la misma operación al desmontar las ruedas.

Par de apriete de las tuercas de ruedas:

- Ø 16 a de 12 a 14 m da N
- Ø 18 a de 26 a 29 m da N
- Ø 22 a de 45 a 50 m da N

No pinte las caras de apoyo de ruedas de los bujes

Bogies:

Engrasar las articulaciones centrales de los soportes de bogie cada mes y comprobar el ajuste de las tuercas de los abarcones.

Ejes direccionales:

Engrasar los ejes de pivote de los ejes direccionales cada mes.





NOTICE ENTRETIEN BOGGIE
MAINTENANCE MANUAL BOGIE
MANUAL MANTENIMIENTO BOGGIE



Ordre de serrage
 Tightening order
 Orden de ajuste

Graisseur M8x1.25
 Grease nipple M8x1.25
 Graseira M8x1.25

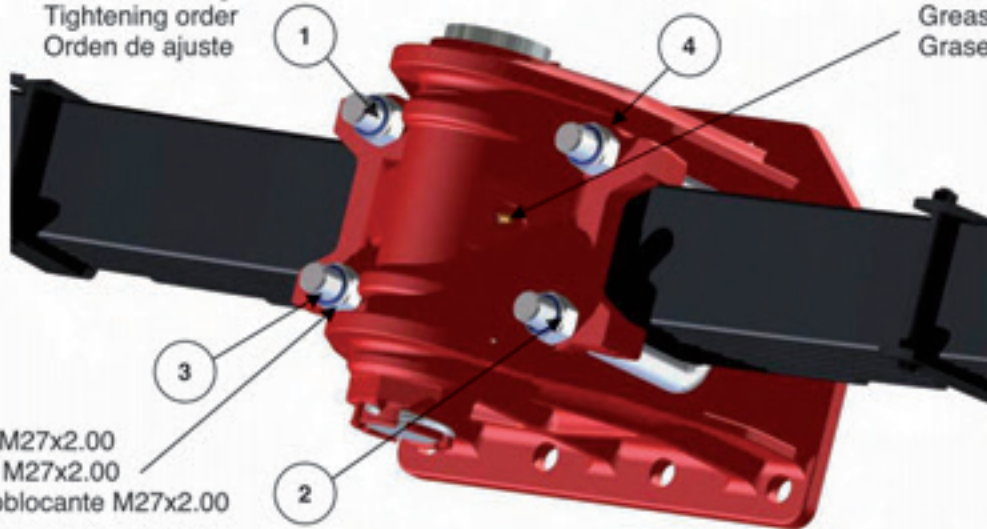

Ecrou frein M27x2.00
 Tighten nut M27x2.00
 Tuerca autoblocante M27x2.00

LIAISON CHASSIS / RESSORT

Il est nécessaire de vérifier certains éléments de la fixation après le 1er voyage en charge puis tous les 6 mois (suivant vos conditions de travail), notamment :

- resserrer les écrous M27 x 2,00 au couple compris entre 60 et 80 daN/m suivant l'ordre indiqué ci-dessus,
- graisser l'axe de pivot situé sous le ressort,
- vérifier suivant les cas le serrage des boutons de fixation du châssis.

CHASSIS FRAME / SPRING

It is necessary to check several elements of the fastening after the first travel under load, and then every 6 months (depending on the conditions of use) and in particular:

- Retighten the nuts M27 x 2,00 with a torque between 60 and 80 da N according to the order stated above,
- Grease the pivot shaft located below the spring,
- Check, according to the cases, the tightening of the nuts of the chassis fastening.

CHASSIS / BALLESTAS

Es preciso comprobar varios elementos de la fijación después del primer viaje bajo carga y luego cada seis meses (según condiciones de uso), y en particular:

- Vuelva a apretar las tuercas M27x2,00 con un par de apriete entre 60 y 80 da N según el orden mencionado más arriba
- Engrase el eje pivote que se encuentra debajo de las ballestas
- Compruebe, según los casos, el ajuste de las tuercas de la fijación del chasis

Plaque caoutchouc
 Rubber plate
 Placa de caucho

Ecrou HU M22x1.50
 Hexagonal head nut M22x1.50
 Tuerca hexagonal M22x1.50

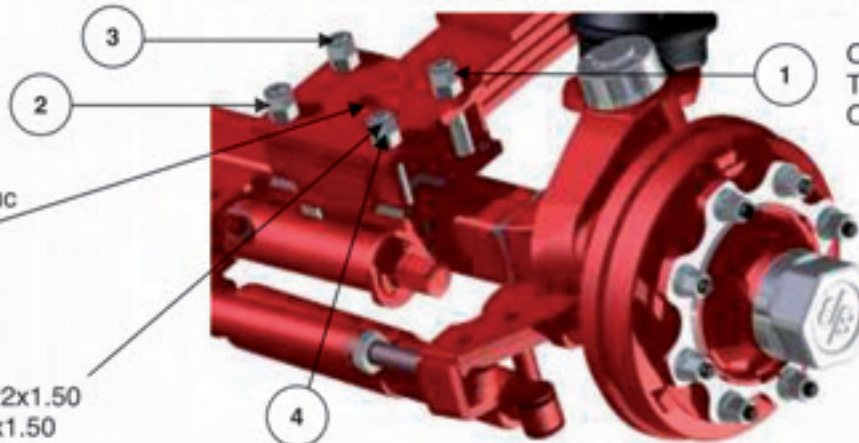

Ordre de serrage
 Tightening order
 Orden de ajuste

LIAISON CHASSIS / ESSIEU

Il est nécessaire de vérifier certains éléments de la fixation après le 1er voyage et en charge puis tous les 6 mois (suivant vos conditions de travail), notamment :

- resserrer les écrous M22 x 1,50 au couple 50 daN/m suivant l'ordre indiqué ci-dessus,
- vérifier l'état d'usure de la plaque caoutchouc située entre le ressort et le coffret.

AXLE / SPRING

It is necessary to check several elements of the fastening after the first travel under load, and then every 6 months (depending on the conditions of use) and in particular:

- Retighten the nuts M22x1,50 with a torque of 50 da N according to the order stated above,
- Check the wear of the rubber plate located between the spring and the box.

EJE / BALLESTAS

Es preciso comprobar varios elementos de la fijación después del primer viaje bajo carga y luego cada seis meses (según condiciones de uso), y en particular:

- Vuelva a apretar las tuercas M22x1,50 con un par de apriete de 50 da N según el orden mencionado más arriba
- Compruebe el estado de desgaste de la placa de caucho situada entre las ballestas y la caja





NOTES

ESSIEUX BOURGOGNE





NOTES

ESSIEUX BOURGOGNE





NOTES

ESSIEUX BOURGOGNE





NOTES

ESSIEUX BOURGOGNE



DIRECTEUR FORCE
 BRIDE TRIDEM
 KIT ABS 40 KM/H
 TAMBOUR
 KIT DPA
 PULVERISATION
 TANDDEM ROULEMENT
 300X90
 ESSIEU FIXE
 BALANCIER 420X180
 BOGGIE
 EPANDAGE MOYEU RESSORT
 350X90
 ESSIEU SUIVEUR
 PARABOLIQUE 250X60
 AMORTISSEUR
 DEMI ESSIEU
 TELEGNONFLAGE



ESSIEUX BOURGOGNE
 42, route de Digoïn
 03510 Molinet - FRANCE
 Tél. (0033) (0)3 85 53 05 34
 Fax (0033) (0)3 85 88 57 52
 accueil@essieux-bourgogne.fr
 www.essieux-bourgogne.com

Septembre 2015

ZI du Coquet
 03260 Saint-Germain-des-Fossés
 FRANCE
 Fax (0033) (0)4 70 58 16 64



ESSEUX.COM
 03 85 53 05 34